



ANNEX GEN 11: Tender Notice



Reference: **RDF/NCA-Telethon/01/05-08-2016/03**

Item number and title: (7)

Contracting Authority: Research and Development Foundation

Deadline for submission of offer: 25th August 2016 at 05:00 pm.

INVITATION TO BID

Research & Development Foundation (RDF) is a non-profit, non-government organization, currently working in District Sanghar and Thatta, Sindh with the assistance from NCA for Strengthen community resilience to floods, and improve access to safe drinking water, adequate sanitation and hygiene in Sanghar and Thatta districts, Sindh Province. Research and Development Foundation is launching a "Local Open Tender" and invites sealed tenders from interested registered suppliers/vendors/ contractors/ candidates to participate in the procurement procedure for the relevant lot(s): for the supply of following items; construction material and construction Work:

S.No	Description	Specification required	Total Quantity
1	Afridev Hand Pumps, Raised Plate Form	Detail in Tender Pack	20
2	Lead line Hand Pump with Raised Plate Form	Detail in Tender Pack	60
3	Hand Pumps (Direct) with Raised Plate Form	Detail in Tender Pack	42
4	Major Repair Hand Pump with Plate Form	Detail in Tender Pack	70
5	Rehabilitation of Dug Wells	Detail in Tender Pack	06
6	Rain Water Harvesting Tanks (Locally Called Tanka) with Catchment	Detail in Tender Pack	110
7	Pour flush Latrine Single Unit	Detail in Tender Pack	3072

Terms and Conditions;

1. All the goods are for a humanitarian project in District Sanghar and Thatta District, Sindh an intervention supported by NCA.
2. All goods are to be delivered at different field locations of District Sanghar and Thatta, Sindh, Pakistan.
3. The offered prices shall be quoted in PKR only.
4. Lowest price will not be the sole criteria. Quality, previous experience and timely delivery will be considered. inser the exclusion. Selection and award criteria.
5. All offers, in English language only, must be delivered to the office mentioned below by 05:00 pm, on 25th August 2016. Late bids will be rejected. Applicants with questions regarding this tender should send then in writing (fax or email) up to 05:00 pm 18th August 2016.



6. Tenders will be opened at the address mentioned below at the time stated in the Tender Dossier. Tenderers or their authorized representative can be present at the opening of tenders.
7. The successful tenderer shall place a 10% Performance Guarantee upon signing of the Contract. 1% call deposit must be submitted along with bid / tender documents.
8. Samples of each item must be submitted on or before 25th August 2016 along with submission of tender document 1 day before tender opening. Non submission of samples might make the bidder in-eligible / unqualified.
9. Tender documents will be available from 5th August 2016, in office timing 09:00 am - 05:00 pm, to 25th August 2016 in office timing till 09:00 am – 12:00 pm from Monday to Friday. Interested tenderers may obtain the Tender Dossier in English at no cost from the Contracting Authority mentioned below and Tender Dossier may also download from RDF website or by sending email at below mentioned.

Research and Development Foundation

House# A-50, Sindhi Muslim Cooperative Housing Society
Qasimabad, Hyderabad.

Contact Person: Ali Dino Bhuwa– Procurement Officer
Telephone Number: 022-2102702-3
Email Address: alidino@rdfoundation.org.pk
Website: www.rdfoundation.org.pk

INVITATION TO TENDER

TO:

Date of issue:	5 th August 2016
Tender no.:	RDF/NCA-Telethon/01/05-08-2016/03
Contract title:	Supply of Construction Material and Construction Work (Civil Work).
Closing date:	25 th August 2016 at 05:00 pm
Tender opening:	26 th August 2016 at 10:30 am
Contracting Authority:	Research and Development Foundation. House# A-50, Sindhi Muslim Cooperative Housing Society Qasimabad, Hyderabad Contact person: Ali Dino Tel: 022-2102702-3 Fax: 0222102704 Email: alidino@rdfoundation.org.pk

RESEARCH AND DEVELOPMENT FOUNDATION INVITES YOU TO TENDER FOR: SUPPLY OF CONSTRUCTION MATERIAL AND CONSTRUCTION WORK (CIVIL WORK)

Dear Sir/Madam

The Services are required for Strengthen community resilience to floods, and improve access to safe drinking water, adequate sanitation and hygiene in Sanghar and Thatta districts, Sindh Province, an intervention supported by NCA.

Please find enclosed the following documents, which constitute the Tender Dossier:

A – Instructions to Tenderers

B – Draft Contract including Annexes:

Annex 1: Terms of Reference

Annex 2: Organisation and Methodology (to be completed by the Tenderer)

Annex 3: Tender Submission Form (to be completed by the Tenderer)

Annex 4: General Terms and Conditions for Service Contracts – Ver2 2012

Annex 5: Code of Conduct for Contractors

If this document is in PDF format, upon request a complete copy of the above documents can be forwarded in WORD format for electronic completion. It is forbidden to make alterations in the text.

We would be grateful if you would inform us by email of your intention to submit or not submit a proposal.

A. INSTRUCTIONS TO TENDERERS

In submitting a proposal the Tenderer accepts in full and without restriction the special and general conditions including annexes governing this Contract as the sole basis of this procedure, whatever his/her own conditions of services may be, which the Tenderer hereby waives. The Tenders are expected to examine carefully and comply with all instructions, forms, contract provisions and specifications contained in this Tender Dossier.

A.1. Scope of services

The Services required by the Contracting Authority are described in the Terms of Reference in Annex 1. The Tenderer shall offer the totality of the Services described in the Terms of Reference. Tenderers offering only part of the required Services will be rejected.

A.2. Cost of participating in tender process

The Tenderer shall bear all costs associated with the preparation and submission of his/her proposal and the Contracting Authority is not responsible or liable for these costs, regardless of the conduct or outcome of the process.

A.3. Clarification of tender documents and additional information

Tenderers may submit questions in writing at the latest on the date specified in the timetable in article A.4, specifying the tender no., and the contract title. Information regarding interpretation of this invitation to tender must be requested in writing to the Contracting Authority's contact person.

Tenderers are not allowed to approach the Contracting Authority for verbal clarification.

Any clarification of the Tender Dossier given by the Contracting Authority will be submitted to all tenderers at the latest on the date specified in the time table. If the Contracting Authority provides additional information on the tender dossier, such information will be sent in writing to all other prospective tenderers at the same time.

Any prospective tenderer seeking to arrange individual meetings during the tender period with either the Contracting Authority and/or any other organisation with which the Contracting Authority is associated or linked may be excluded from the tender procedure.

A.4. Planned time table

The Contracting Authority reserves the right to alter the dates and times in the following timetable, in which case all tenderers will be informed in writing and a new timetable will be provided.

	Date	Time
Deadline for request for any clarifications from the Contracting Authority	18 th August 2016 Thursday	05:00pm
Last date on which clarifications are issued by the Contracting Authority	19 th August 2016 Tuesday	04:00pm
Deadline for submission of tenders (closing date)	25 th August 2016	05:00 pm
Tender opening session	26 th August 2016	10:30 am
Contract award	6 th September 2016	03:00 pm
Contract start	8 th September 2016	11:00 am

All times are in the time zone of Pakistan.

A.5. Eligibility and qualification requirements

Tenderers are not eligible to participate in the tender procedure if they are in one of the situations listed in article 33 of the General Terms and Conditions for Service Contracts – Ver2 2012.

Tenderers shall in the Tender Submission Form attest that they meet the above eligibility criteria. If required by the Contracting Authority, the Tenderer whose tender is accepted shall further provide evidence satisfactory to the Contracting Authority of its eligibility through certificates issued by competent authorities in its country of establishment or operation, or, if such certificates are not available, through a sworn statement.

Tenderers are also requested to certify that they comply with the Code of Conduct for Contractors, as well as to give evidence of their capability and adequate resources tenderers shall provide the information and the documents requested in the Tender Dossier.

A.6. Exclusion from award of contracts

Contracts may not be awarded to Tenderers who, during the procurement procedure:

- (a) are subject to conflict of interest; and/or
- (b) are guilty of misrepresentation in supplying the information required as a condition of participation and eligibility in the tender procedure or fail to supply this information.

A.7. Language of Tenders

The tenders, all correspondence and documents related to the Tender exchanged by the Tenderer and the Contracting Authority must be written in English.

A.8. Documents comprising the Tender

The Tenderer shall complete and submit the following documents with his/her tender:

- a) Tender Submission Form (Annex 3) with supporting documents and duly completed and signed by the Tenderer
- b) Organisation and Methodology using the structure in Annex 2
- c) CV highlighting the Tenderers experience in the specific field of the Services and his/her specific experience in the country/ region where the Services are to be performed;
- d) Copies of Tenderer's audited financial statement for the last three years.
- e) Evidence of any quality accreditation or ISO Certifications
- f) **PEC Registration Certificate and FBR Registration Certificate**
- g) Performance Guarantee
- h) Tender Guarantee

And other relevant information that should be made known to the Contracting Authority.

A.9. Tender Guarantee

All tenders must be accompanied by a Tender Guarantee of minimum 1% of the total tender amount. The guarantee shall be issued in favour of the Contracting Authority and be valid for 45 days beyond the period of validity of the Tender. The Tender Guarantee shall be issued in the form of a first demand guarantee, by an internationally recognised bank or other financial institution, and shall be in accordance with the text in the attached guarantee. The Tender Guarantee may also be issued in the form of a banker's draft, a certified cheque, a bond provided by an insurance company or an irrevocable letter of credit, as long as it creates under the applicable law the same irrevocable, at-first-demand obligations for the guarantor as expressed in the wording of the attached guarantee.

A.10. Financial proposal

The Financial Proposal shall be presented as an amount in PKR in the Tender Submission Form in Annex 3. The price proposed by the Tenderer shall not be subject to adjustments except as otherwise provided in the conditions of the Contract.

For evaluation purpose, where proposals are given in PKR, it shall be converted into EUR at the rate published in State Bank of Pakistan on the closing date.

The remuneration of the Contractor under the Contract shall be determined as follows:

VAT and/or any sales tax applicable to the purchase of services shall be indicated separately in the Tender Submission Form.

A.11. Tenderers proposed personnel

In the Organisation and Methodology, Annex 2, the Tenderer shall include a detailed description of the role and duties of each of the key experts or other non-key experts, which the Tenderer proposes to use for the performance of the Services. The key experts are those whose involvement is considered instrumental in the achievement of the contract objectives. The Tenderer whose proposal is accepted shall provide, if so requested by the Contracting Authority, copies of diplomas and employers' certificates or references proving the key experts' education, professional experience and language proficiency.

In the Tender Submission Form, Annex 3, the Tenderer shall provide detailed information about key experts' actual availability for the performance of the Contract.

If, before the signing of the Contract, a key expert proposed in the proposal is no longer available the Tenderer shall inform the Contracting Authority immediately and the proposal will in such case be considered invalid.

A.12. Subcontractors

If the Tenderer intends to use subcontractors, the Tenderer shall state in the Organisation and Methodology, Annex 2, their names, qualifications, role and duties in the performance of the Contract and the Tenderer shall specify the parts of the Services which will be executed by the subcontractors, which may not exceed 30% of the Contract. Provisions of article "Tenderers proposed personnel" concerning the Tenderers personnel and the article concerning eligibility and qualification requirements shall apply to the subcontractors or the subcontractor's personnel.

A.13. Validity

Tenders shall remain valid and open for acceptance for 90 days after the closing date for the submission of tenders.

Prior to the expiry of the tender validity period, the Contracting Authority may ask tenderers in writing to extend this period. Tenderers that agree to do so will not be permitted to modify their tenders. If they refuse, their participation in the tender procedure will be terminated.

A.14. Submission of tenders and closing date

Tenders must be received at the address mentioned below by hand or post not later than the closing date and time specified in the time table article A.4. Any tenders received after that time will not be considered. Tenders shall be submitted in a sealed envelope bearing the following information:

Research and Development Foundation
House# A-50, Sindhi Muslim Cooperative Housing Society, Qasimabad, Hyderabad.

Attention: Procurement Section
Tender receipt: 25th August 2016 at 05:00 pm
Tender no.: **RDF/NCA-Telethon/01/05-08-2016/03**

**TENDERS ARE NOT OPENED BEFORE THE TENDER OPENING SESSION ON:
FRIDAY 26th August 2016 AT 10:30 AM**

All tenders must be submitted in one original, marked "original" and 1 copy signed in the same way as the original and marked "copy".

No tender may be changed or withdrawn after the deadline has passed.

A.15. Tender opening

Tenderers are invited to attend the tender opening. Tenderers are requested to advise the contact person, at least one day in advance of the tender opening if they will attend.

Tender opening will take place at **RDF Head Office House# A-50, Sindhi Muslim Cooperative Housing Society Qasimabad, Hyderabad** at the time and date specified in article A.4. Tenderers representatives who are present shall sign a register indicating their attendance.

At the tender opening, only the Tenderers names, the total amount of the tenders and any discount offered will be read aloud and recorded.

A.16. Evaluation of Tenders

Prior to the detailed evaluation of the tenders, the evaluation committee, (established by the Contracting Authority for the purposes of this tender procedure), shall ascertain whether the tenders meet the eligibility requirements; have been properly signed, are substantially responsive to the tender documents; have any material errors in computation; and are otherwise generally in order.

If a tender is not substantially responsive i.e. it contains material deviations from or reservations to the Terms of Reference and/or conditions in the tender dossier, it shall not be considered further.

After analysing the substantially responsive tenders, the evaluation committee will examine the technical admissibility of each tender, classifying it as technically compliant or non-compliant. Deviations from the Terms of Reference may be considered if deemed to be in the best interest of the Contracting Authority.

Tenders determined to be substantially responsive and technically compliant will be checked by the evaluation committee for any arithmetic errors. Where there is a discrepancy between the amounts in the figures and words, the amount in words will govern. If a Tenderer refuses to accept the correction, his/her tender will be rejected.

Evaluation method

The evaluation method will be the quality and cost based selection. A two-stage procedure shall be utilised in evaluating the tenders; a technical evaluation and a financial evaluation.

Tenders will be ranked according to their combined technical (S_t) and financial (S_f) scores using the weights of 75% for the technical proposal; and 25% for the offered price. Each tender's overall score shall therefore be: $S_t \times 75\% + S_f \times 25\%$.

Technical evaluation

For the evaluation of the technical proposals, the Contracting Authority shall take the following criteria into consideration, with the indicated weights:

Here are given two types of evaluation formats (**A and B**) and scoring format with a little change but the major points are coverable for both formats to check qualifying a tenderer. Contracting Authority may analyses technical evaluation by using any one sort of (**A or B**) below options.

A.

Technical evaluation		Maximum Points
Expertise of the Candidate submitting proposal		
1	Tenderers economic and financial capacity	4
2	Tenderers technical capacity	3
3	Extent to which any service would be sub-contracted	4
4	Availability of quality assurance procedures and quality accreditations	4
5	Organisation's specialised knowledge and experience in the field of assignment and selected region	3
6	Tenderers overall relevant academic qualifications	3
7	Tenderers overall relevant experience in the field of assignment	3
8	Tenderers experience in the region/country e.g. knowledge of local language, culture, administrative system, government etc.	3
9	Tenderers proficiency in English	3
10	Tenderers CSR related policies – e.g. HR policy, health and safety policy, energy policy, climate policy, Global Compact membership etc.	5
11	CSR related standards/certifications-e.g. ISO26000/50001/140000 or SA80000 certification	5
Sub-total individual Tenderer and/or Company		40
1	To what degree does the proposal show understanding of the task?	8
2	Have the Terms of Reference been addressed in sufficient detail?	8
3	Is the conceptual framework adopted appropriate for the task?	8
4	Is the sequence of activities and the planning logical, realistic and promising efficient implementation to the Contract?	8
5	Is the work plan adequate in responding to the Terms of Reference	8
Sub-total Organisation and Methodology		40
1	Key Expert's relevant academic qualifications	-
2	Key Expert's relevant experience in the field of assignment	10
3	Key Expert's experience in the region/country e.g. knowledge of local language, culture, administrative system, government etc.	10
4	Key Expert's proficiency in English language	-
Sub-total Key expert		20
Total Technical Score		100

B.

Technical evaluation	Maximum Points
NTN Registration No#	10
PEC Registration Certificate	10
Previous Experience	10
Economic Financial Capacity	5
Tenderers technical capacity	10
Audited Financial Statements	5
Quality Assurance	10
Delivery/ Completion Time Period	5

Bid Security	5
Sample Assessment	30
Total Technical Score	100

Financial evaluation

Each proposal shall be given a financial score. The lowest Financial Proposal (Fm) will be given a financial score (Sf) of 100 points. The formula for determining the financial scores shall be the following:

$S_f = 100 \times F_m / F$, in which

Sf is the financial score

Fm is the lowest price and

F is the price of the proposal under evaluation

A.17. Award Criteria

The Contracting Authority will award the contract to the Tenderer whose tender has been determined to be substantially responsive to the Tender Dossier and technically compliant, and who has obtained the highest overall score, provided further that the Tenderer has demonstrated the capability and resources to carry out the contract effectively.

A.18. Signature and entry into force of the Contract

Prior to the expiration of the tender validity period, the Contracting Authority will inform the successful Tenderer in writing that its tender has been accepted and inform the non-successful tenderers in writing about the result of the evaluation process.

The Contracting Authority reserves the right to adjust the services within a range of +/- 25% to remain within the available funds.

Within 7 days of receipt of the Contract, not yet signed by the Contracting Authority, the successful Tenderer must sign and date the Contract and return it with the Performance Guarantee to the Contracting Authority on signing the Contract, and subject to the provision of a valid Performance Guarantee, the successful Tenderer will become the Contractor and the Contract will enter into force once signed by the Contracting Authority.

If the successful Tenderer fails to sign and return the Contract and the Performance Guarantee within the days stipulated, the Contracting Authority may consider the acceptance of the Tender to be cancelled without prejudice to the Contracting Authority's right to seize the Tender Guarantee, claim compensation or pursue any other remedy in respect of such failure, and the successful Tenderer will have no claim whatsoever on the Contracting Authority.

A.19. Performance Guarantee

Within 7 days of receipt of the Contract from the Contracting Authority, the successful Tenderer shall, furnish a Performance Guarantee in accordance with Article B.16 of the Draft Contract.

A.20. Cancellation for convenience

The Contracting Authority may for its own convenience and without charge or liability cancel the tender process at any stage.

B. DRAFT CONTRACT (SERVICE)

CONTRACT TITLE: SUPPLY OF CONSTRUCTION MATERIAL, CONSTRUCTION WORK AND SUPPLY OF SURGICAL EQUIPMENT FOR WASH ACTIVITIES

Contract no.: RDF/NCA-HEKS/04/20-05-2016/10

Instructions to tenderers: at this stage of the tender preparation this Draft Contract document is for your information and intended to make you aware of the contractual provisions. The information missing in this document will be filled in when a successful Tenderer has been selected, and the “Draft” Contract will then become the “final” Contract” between the Contracting Authority and the Contractor

Research and Development Foundation
House# A-50, Sindhi Muslim Cooperative Housing Society
Qasimabad, Hyderabad

("The Contracting Authority"),
of the one part,

and

("the Contractor")
of the other part,

have agreed as stipulated in the attached document.

The Contract is done in English in three originals, two originals being for the Contracting Authority and one original being for the Contractor.

For the Contractor

Name:

Title:

Signature:

Date:

For the Contracting Authority

Name:

Title:

Signature:

Date:

Special Conditions

B.1. Scope of services

The subject of the Contract is Supplies and Constructions at different field locations of District Sanghar and Thatta, Sindh, Pakistan. The "Supplies and Services" are described in the Terms of Reference and further specified in the Organisation and Methodology.

The Contractor acknowledges that:

- a) The Contracting Authority is not obligated to place any minimum number of contract with the Contractor, pursuant to this Contract;
- b) The Contracting Authority shall not be liable for any cost in the event that no contract is placed under this Contract; and
- c) This Contract is nonexclusive, and the Contracting Authority is entitled to procure the same or similar services from other Contractors, as it sees fit.

B.2. Commencement Date and Period of Implementation

The Contract shall commence after signature of this Contract by both parties and on the date the Contractor provides to the Contracting Authority the Performance Guarantee. The period of implementation of the services is [] weeks from the commencement date.

B.3. Terms and Termination

The Contract is valid for a period of 12 months, and commences on the commencement date and expires at midnight on the expiry date, unless earlier termination in accordance with the General Terms and Conditions for Service – Ver2 2012 of this Contract.

The Contracting Authority shall be entitled to renegotiate the Contract for a further period of 12 months on similar terms and conditions, by giving the Contractor written notice of its intention to renegotiate the Contract not less than 30 days prior to the expiry date, provided however that in the event of a breach of the Agreement by one of the Parties, the other party may for valid cause terminate the Contract as per General Terms and Conditions for Service – Ver2 2012, article 26 and 27.

B.4. Delivery of Services

The Contracting Authority will issue contracts to the Contractor, during the term of this Contract, marking reference to this Contract, and setting out the services required, the location and timing and other instructions for the delivery of Services.

The Contractor agrees to deliver Services to the Contracting Authority pursuant to the Contract, which shall conform to the Terms of References, Annex 1, Organisation and Methodology, Annex 2) and the price specified in this Contract.

In the event of the Contracting Authority placing a contract, which the Contractor considers it cannot substantially meet because of unavailability of staff or inability to meet the Terms of References, before proceeding to make a partial delivery of the services, the Contractor shall seek further written instructions from the Contracting Authority.

The Contractor shall cover all costs related to the remedy of an unacceptable Service.

The Contractor shall be responsible for providing all the necessary personnel, equipment, materials and supplies and for making all necessary arrangement for the performance of its obligations under this Contract.

B.5. Remuneration

VAT and/or any sales tax applicable to the purchase of services shall be indicated separately in the Contract.

The Contractor guarantees that the price specified in this Contract, are the maximum price that shall remain firm and shall not be increased during the entire term of this Contract, provided however, that in the event that the Contractor is able to offer the Contracting Authority a discounted price on placement of bulk contracts, the unit price shall be reduced for specific contracts.

By signing this Contract, the Contractor certifies that the Contracting Authority, for transactions resulting from this Contract is not being charged more than other clients for similar services and within similar circumstances.

B.6. Reporting

The Contractor shall submit reports as specified in the Terms of Reference, Annex 1. The Contractor shall keep the Contracting Authority updated on contract progress on a regular basis.

B.7. Payment

Payments shall be made in PKR through cross cheque or by bank transfer to the following account: [if provided]

Account Number:

Name of Bank:

Address of Bank:

Account name:

Swift Code:

Payment will be made by the Contracting Authority within 20-30 days from approval by the Contracting Authority and receipt of the Contractor's invoice, Delivery Challans and Work Completion Certificates and inspection reports by field staff.

B.8. Tax and social contributions

The Contracting Authority shall have no obligation or responsibility in connection with taxes or levies payable by the Contractor in its country of establishment or in the beneficiary country in connection with its performance of this Contract.

This Contract is exempt from all duties and taxes, including VAT.

B.9. Liability

The Contractor will meet without limitation the liability obligations as stated in the General Terms and Conditions for Service Contracts Ver2 2012 article 15.

B.10. Order of precedence of contract documents

The Contract is made up of the following documents, in order of precedence:

1. This Contract
2. Terms of Reference (Annex 1)
3. Organisation and Methodology (Annex 2)
4. Tender Submission Form (Annex 3)
5. General Terms and Conditions for Service Contracts - Ver2 2012 (Annex 4)
6. Code of Conduct for Contractors (Annex 5)

The various documents making up the Contract shall be deemed to be mutually explanatory; in cases of ambiguity or divergence, they should be read in the order in which they appear above.

B.11. Language

The language of this contract and of all written communications between the Contractor and the Contracting Authority shall be English.

B.12. Entry into force and duration

The Contract shall enter into force and effect after signature by both parties of this Contract. The Contract shall remain into force and effect until the end of the liability period as defined in the General Terms and Conditions for Service Contracts - Ver2 2012.

B.13. Performance Guarantee

The Contractor shall, together with the return of the countersigned Contract, furnish the Contracting Authority with a guarantee for the full and proper execution of the Contract. The entry into force of the Contract shall be subject to the provision of the Performance Guarantee by the Contractor.

The amount of the guarantee shall be of 10% of the total contract amount and shall be denominated in the currency in which the Contract is payable, i.e. PKR.

The Performance Guarantee shall be held against payment to the Contracting Authority for any loss resulting from the Contractor's failure to perform his/her contractual obligations fully and properly.

The Performance Guarantee shall be issued in the form of a first demand guarantee, by an internationally recognised bank or other financial institution, and shall be in accordance with the text attached. The Performance Guarantee may also be issued in the form of a banker's draft, a certified cheque, a bond provided by an insurance company or an irrevocable letter of credit, as long as it creates under the applicable law the same irrevocable, at-first-demand obligations for the guarantor as expressed in the wording of the attached document.

The Contracting Authority shall demand payment from the guarantee of all sums for which the guarantor is liable under the guarantee due to the Contractor's default under the Contract, in accordance with the terms of the guarantee and up to the value thereof. The guarantor shall, without delay, pay those sums upon demand from the Contracting Authority and may not raise any objection for any reason whatsoever. Before making any claim under the Performance Guarantee, the Contracting Authority shall notify the Contractor stating the nature of the default in respect of which the claim is to be made.

The guarantee shall continue to remain valid until the Contract has been fully and properly performed.

The Contracting Authority shall, upon request, return the Performance Guarantee to the Contractor after completion of the Contract.

B.14. Notices

Any written communication relating to this Contract between the Contracting Authority and the Contractor must state the contract title and contract number, and must be sent by post, fax, e-mail or by hand to the addresses identified in this Contract.

B.15. General Terms and Conditions

The Contracting Authorities' General Terms and Conditions attached shall apply to this Contract and all contracts subsequently issued pursuant to this Contract.

ANNEX 1: TERMS OF REFERENCE

- **BACKGROUND INFORMATION**

Research & Development Foundation (RDF) is a non-profit, non-governmental organization currently working in District **Sanghar and Thatta** with support of NCA-**Teleton** project for **Strengthen community resilience to floods, and improve access to safe drinking water, adequate sanitation and hygiene in Sanghar and Thatta districts, Sindh Province.**

- **CONTRACT PURPOSE AND EXPECTED RESULTS**

Results to be achieved by the Contractor:

1. (20 units) Afridev Hand Pumps with Raised Plate Form (6ft x 5ft x 2ft)
2. (60 units) Lead line Hand Pump with Raised Plate Form (Size 4ft X 5ft X 3ft).
3. (42 units). Hand Pumps (Direct) with Raised Plate Form (4ft X 5ft x 1.75ft)
4. (70 units) Major Repair Hand Pump with Plate Form (Size 4ft X 4ft).
5. (06 units) Rehabilitation of Dug Wells.
6. (110 units) Construction of Rain Water Harvesting Tanks (Locally Called Tanka) with Catchment.
7. (3072 units) Pour flush Latrine Single Unit.

- **SCOPE OF THE SERVICES**

The scope of assignment relates to the supply of construction materials and the construction (as per specification), but is not limited to transport up till the site of delivery i.e. District **Sanghar and Thatta**.

The tasks to be carried out by the Contractor

Lot# 1. (20 units) Afridev Hand Pumps with Raised Plate Form (6ft x 5ft x 2ft)

Type Of Scheme:		(20 units) Afridev Hand Pumps with Raised Plate Form (6ft x 5ft x 2ft)			
S No.	Item	Descriptions	Unit	Unit Quantity	Total Quantity
1	Bricks	First class bricks (9" * 3" * 4.5")	No.s	1164	23280
2	Cement	Lucky or Pakland	Bags	9	180
3	Sand	Fine Sand	Cft	63	1260
4	Crush	Size 1/2"- 3/4" dia	Cft	20	400
5	Gravel (Shouting)	Size as per need	Cft	60	1200
6	Drilling Bore	Drilling 6" dia through machine	Rft	120	2400
7	Casing Pipe	Pressure Pipe C-Class 4" dia (Prince Company)	Rft	130	2600
8	Filter	Pressure Pipe C-Class 4" dia (Prince Company)	Rft	10	200
9	Suction Pipe	Pressure Pipe C-Class 2" dia (Prince Company)	Rft	70	1400
10	GI Rod	Dia 12mm	Rft	70	1400
11	GI Rod Seals	Rubber Paking Seals	No.s	6	120
12	Cone Seal	Rubber Paking Seals	No.s	1	20
13	Wire Rope	Steel Rope	Rft	60	1200
14	UPVC-Pipe	4"dia Pipe Jeddah/Pak Al arab	Rft	20	400
15	Elbow	4" dia UPVC Prince Company	No.s	2	40
16	Steel Jali	6" dia (Circular)	No.s	1	20
17	Afridev Hand Pump Machine with stand	Indus Company	No.s	1	20
18	Nut & Bolt Set	Size (1.5" & 2") dia 5/8"	No.s	1	20
19	Solution	TZ/AGM 450gm	No.s	2	40
20	End Plug	Dia 2"	No.s	1	20
21	Maintanance Kit	(Fishing rod 01 No.s, Cone seal 01 No.s, Rod Seal 12 No.s, Plunger 01 No.s, Fix Pano 5/8" 01 No.s, Boki 03 No.s, Plumbing bag 01 No.s)	No.s	1	20
22	Fitting Charges of Hand Pump Machine	Skilled Labour Charges	No.s	1	20
23	Labour Charges of Platform	Skilled Labour Charges	Days	3	60

Note: Unit rate for all items to be quoted by supplier on company letter heads.

Lot# 2. (60 units) Lead line Hand Pump with Raised Plate Form (Size 4ft X 5ft X 3ft).

Type Of Scheme:		(60 units) Lead line Hand Pump with Raised Plate Form (Size 4ft X 5ft X 3ft).			
S No.	Item	Description	Unit	Unit Quantity	Total Quantity
1	Bricks	First class bricks (9" * 3" * 4.5")	No.s	877	52620
2	Cement	Lucky or Pakland	Bags	5	300
3	Sand	Fine sand bolari	Cft	41	2460
4	Crush	Size (1/2"- 3/4") dia stone	Cft	13	780
5	Gravel/Stone Ballast	Size (2"-2.5") Round Gravel	Cft	18	1080
6	UPVC-Pipe	4"dia Pipe jeddah/pak Al arab	Rft	12	720
7	Drilling Bore	3" dia manually	Rft	70	4200
8	Casing Pipe	UPVC Pipe 3" dia	Rft	70	4200
9	Suction Pipe	1.25" Dia National PVC Pipe (wt 48-50kg/500 rft)	Rft	60	3600
10	Filter /Jali	UPVC with Colth Filter	No.s	1	60
11	Elbow	UPVC 4" dia	No.s	2	120
12	Steel Jali	Size 6" X 6"	No.s	1	60
13	Hand Pump Machine (IILL - 2.5"dia)	6ft Long machine including 1ft brass cylinder (weight of cylinder is 1.5kg) with all brass accessories	No.s	1	60
14	Check wall	1.5" dia Brass (Khalil Company)	No.s	2	120
15	Lead Line Pipe	1.25" Dia National PVC Pipe (wt 48-50kg/500 rft)	Rft	1000	60000
16	Lead Line Excavation	Unskilled Labour Community			
17	Lead line Fitting Material	GI Elbow#1, PVC Elbow#2, Valve Socket #2, Solution TZ/AGM)	No.s	1	60
18	Construction Charges (Plate Form)	Skilled Labour Charges	Days	2	120

Note: Unit rate for all items to be quoted by supplier on company letter heads.

Lot# 3. (42 units). Hand Pumps (Direct) with Raised Plate Form (4ft X 5ft x 1.75ft)

Type Of Scheme:		(42 units). Hand Pumps (Direct) with Raised Plate Form (4ft X 5ft x 1.75ft).			
S No.	Item	Descriptions	Unit	Unit Quantity	Total Quantity
1	Bricks	First class bricks (9" * 3" * 4.5")	No.s	486	20412
2	Cement	Lucky or Pakland	Bags	4	168
3	Sand	Fine Sand bolari	Cft	25	1050
4	Crush	Size (1/2"- 3/4") dia stone	Cft	13	546
5	Gravel/Stone Ballast	Size (2"-2.5") Round Gravel	Cft	10	420
6	UPVC-Pipe	4"dia Pipe Jeddah/ Al arab	Rft	12	504
7	Drilling Bore	4" dia manually	Rft	65	2730
8	Casing Pipe	UPVC 3" dia	Rft	65	2730
9	Suction Pipe	1.25" Dia National PVC Pipe (Weight 48-50kg / 500 rft)	Rft	40	1680
10	Filter /Jali 10 ft	UPVC with Colth Filter	No.s	1	42

11	Elbow	4" dia UPVC	No.s	2	84
12	Steel Jali	6" dia	No.s	1	42
13	Hand Pump Machine (IILL - 2.5"dia)	6ft Long machine including 1ft brass cylinder (weight of cylinder is 1.5kg) with all brass accessories	No.s	1	42
14	Construction Charges	Skilled Labour (Plateform)	Days	2	84

Note: Unit rate for all items to be quoted by supplier on company letter heads.

Lot# 4. (70 units) Major Repair Hand Pump with Plate Form (Size 4ft X 4ft).

Type Of Scheme:		(70 units) Major Repair Hand Pump with Plate Form (Size 4ft X 4ft).			
S No.	Item	Descriptions	Unit	Unit Quantity	Total Quantity
1	Bricks	First class bricks (9" * 3" * 4.5")	No.s	268	18760
2	Cement	Lucky or Pakland	Bags	3	210
3	Sand	Fine Sand bolari	Cft	31	2170
4	Crush	1/2"- 3/4" dia stone	Cft	8	560
5	Gravel/Stone Ballast	Size (2"-2.5") Round Gravel	Cft	15	1050
6	UPVC-Pipe	4"dia Pipe Jeddah/Pak Al arab	Rft	12	840
7	Elbow	4" dia UPVC	No.s	2	140
8	Steel Jali	6" dia	No.s	1	70
9	Hand Pump Machine (IILL 2.5"dia)	10 ft Long pipe including 1ft Cylinder brass weight of cylinder is 1.5 kg with all brass accessories	No.s	1	70
10	Pipe Nipple	GI Pipe Nipple 1.25" dia, 1.5ft long	No.s	1	70
11	Handle	Hand pump machine long handle	No.s	1	70
12	Piston	Cylinder brass weight of cylinder is 1.5 kg with all brass accessories	No.s	1	70
13	Fixing of Hand Pump Machine	Skilled Labour	No.s	1	70
14	Construction Charges (Plate Form)	Skilled Labour	No.s	2	140

Note: Unit rate for all items to be quoted by supplier on company letter heads.

Lot# 5. (06 units) Rehabilitation of Dug Wells.

Type Of Scheme:		(06 units) Rehabilitation of Dug Wells.			
S No.	Item	Descriptions	Unit	Unit Quantity	Total Quantity
1	Bricks	First class bricks (9" * 3" * 4.5")	No.s	4496	26,976
2	Cement	Lucky or Pakland	Bags	31	186
3	Sand	Fine Sand bolari	Cft	197	1,182
4	Crush	Size (1/2"- 3/4") dia stone	Cft	74	444
5	Iron pully for suction work	circuler dia (15"-18")with bering system.	No.s	1	6
6	Channel patti.	av length 10 rft (size of channel 6"x3"x3" av wt 7 kgs per/RFT.	KGS	70	420
7	Iron gril	for top cover dug well and enterance gate with appropriate design. (av wt 1.5 kgs/rft.)	KGS	130	780
8	Cotton rope.	1"-1.5" thick dia rope for suction work.	Rft	150	900
9	UPVC-Pipe	4"dia Pipe Jeddah/ Al arab	Rft	20	120
10	Elbow	4" dia UPVC	No.s	2	12
11	Steel Jali	6" dia -circuler.	No.s	4	24
12	Desiltaton of Dug well	Labor chage	No.s	30	180
13	Construction Charges	Skilled Labour (Plate Form)	Days	4	24

Note: Unit rate for all items to be quoted by supplier on company letter heads.

Lot# 6. (110 units) Construction Material and Work for Communal Rain Water Hervesting Tanks.

Type Of Scheme:		(110 units) Construction Material and Work for Communal Rain Water Hervesting Tanks.			
S No.	Item	Descriptions	Unit	Unit Quantity	Total Quantity
1	Cement	Lucky or Pakland (OPC)	Bag	7	770
2	Sand local	Lacally Available	Cft	8	880
3	Fine Sand (Cft)	Fine sand bolari	Cft	31	3410
4	Crush	1/2"- 3/4" dia stone	Cft	16	1760
5	Bricks	First class bricks (9" * 3" * 4.5")	Nos	200	22000
6	Bricks Pebbles	First class bricks (9" * 3" * 4.5")	Cft	0	0
7	Iron Frame (Tanka Cover)	Iron Frame (1.5' X 1.5') with Gate weight 5kg	Nos	2	220
8	Sieves (Steel Jallee)	4"-dia circuler.	Nos	4	440
9	U PVC Pipe 4" dia	4"dia pipe Al-jeddah/pak Al arab 9" length 4-pices.	Nos	4	440
10	Skilled	-	M.Day	2	220
11	Unskilled	-	M.Day	3	330

Lot# 7. (3072) Pour flush Latrine Single Unit.

Type Of Scheme:		Lot# 7. (3072) Pour flush Latrine Single Unit.			
S No.	Item	Descriptions	Unit	Unit Quantity	Total Quantity
1	Cement	OPC(Pak land, falcom, zeal pak, Power, Luchy,DG)	Bag	1	3072
2	Bricks	Class-A, (properly burnt, non porous, well dressed,size9"x4.5"x3")	No	100	307200
3	Hill Sand	Fine grained with out boulders	Cft	10	30720
4	Crush	3/4" angular	Cft	2	6144
5	WC Indian medium size	Indian WC medium size 22 inch (Saga/Kareem/3star)	No	1	3072
6	P-Trap ceramic	P-Trap ceramic (good quality)	No	1	3072
7	UPVC-PIPE 4" Dia	U PVC Pipe 4"dia Al-Jeddah Al-Arab	Rft	10	30720
8	UPVC Tee 4" X 3"	U PVC Tee Al-Jeddah Al-Arab	No	1	3072
9	upvc-cowel 3"-dia.	UPVC Cowel	Set	1	3072
10	wash room door.	size of door (2.25"x5') with iron angle frame 1"x1"x1" and GI-Sheet 24-26 guage ith design plain patti-3/4"x1".av:wt: 10 kgs.	No	1	3072

Note: Unit rate for all items to be quoted by supplier on company letter heads.

Note: Approved designs for all construction activities are attached.

Layout Plan of Afridev Hand Pump Raised Plate Form (Size 6ft x 5ft x 2ft)

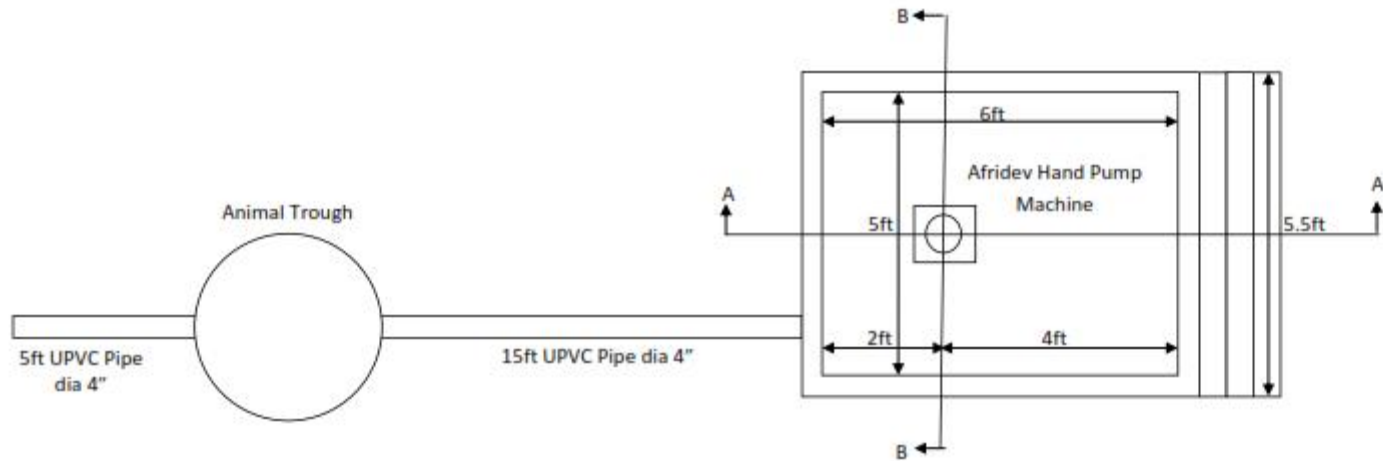

Plan of Hand Pump Raised Plate Form
(Afridev Hand Pump)

Prepared by: Mohsin Ali Qureshi
Senior Project Engineer-RDF

Drawing No. 01



Cross-section-AA of Hand Pump Raised Plate Form

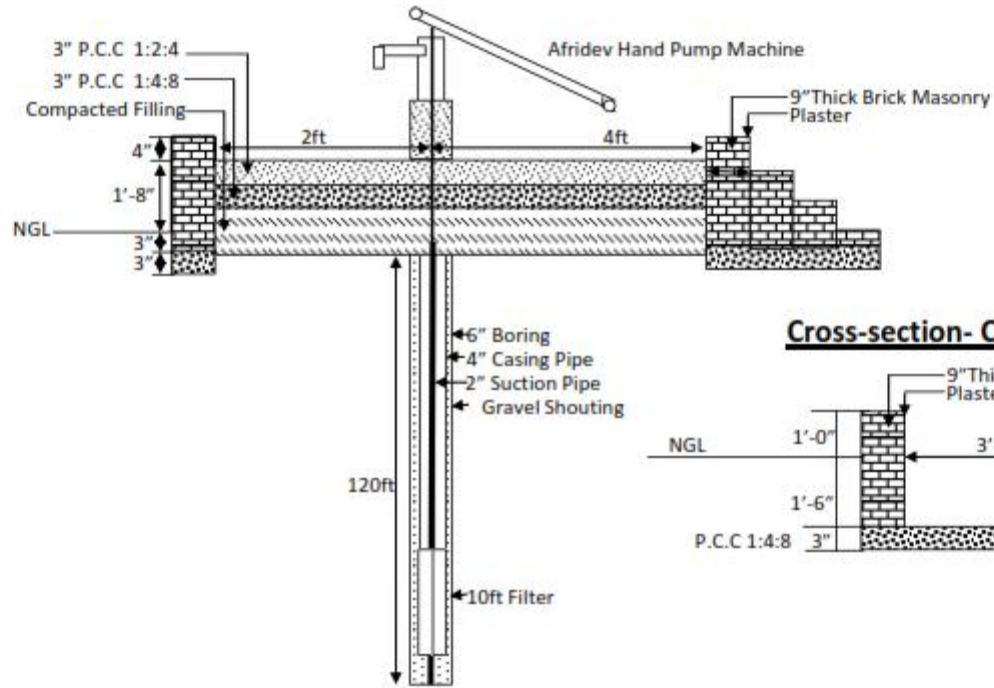

Cross-section- CC of Animal Trough

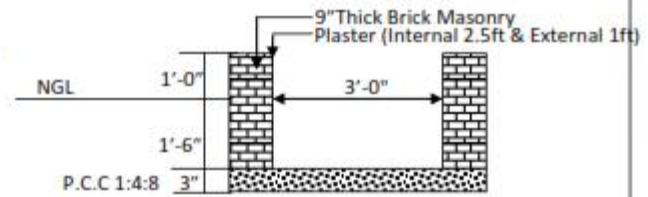

Cross-section-AA of Hand Pump Raised Plate Form (Afridev Hand Pump) & Cross-section-CC of Animal Trough

Prepared by: Mohsin Ali Qureshi
Senior Project Engineer-RDF

Drawing No. 02



Cross-section-BB of Hand Pump Raised Plate Form

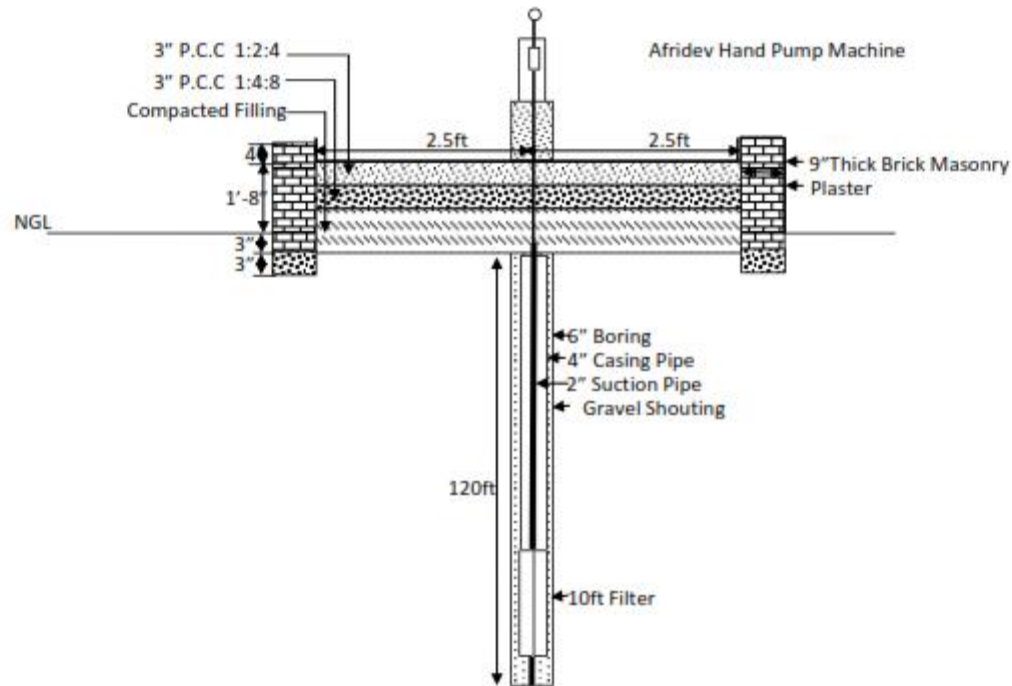

Cross-section BB of Hand Pump Raised Plate Form (Afridev Hand Pump)

Prepared by: Mohsin Ali Qureshi
Senior Project Engineer-RDF

Drawing No. 03



Layout Plan of Lead Line Hand Pump Raised Plate Form (Size 5ft x 4ft x 3ft)

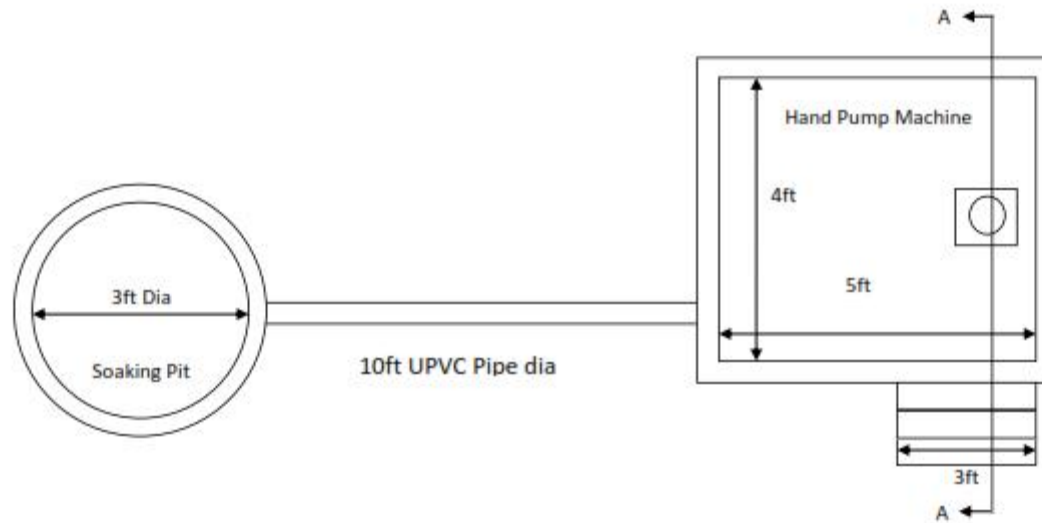

Prepared by:
Mohsin Ali Qureshi
Project Engineer-RDF

Drawing # 01
Layout Plan of Lead Line Hand Pump
Raised Plate Form



Cross-section of Lead Line Hand Pump & Raised Plate Form

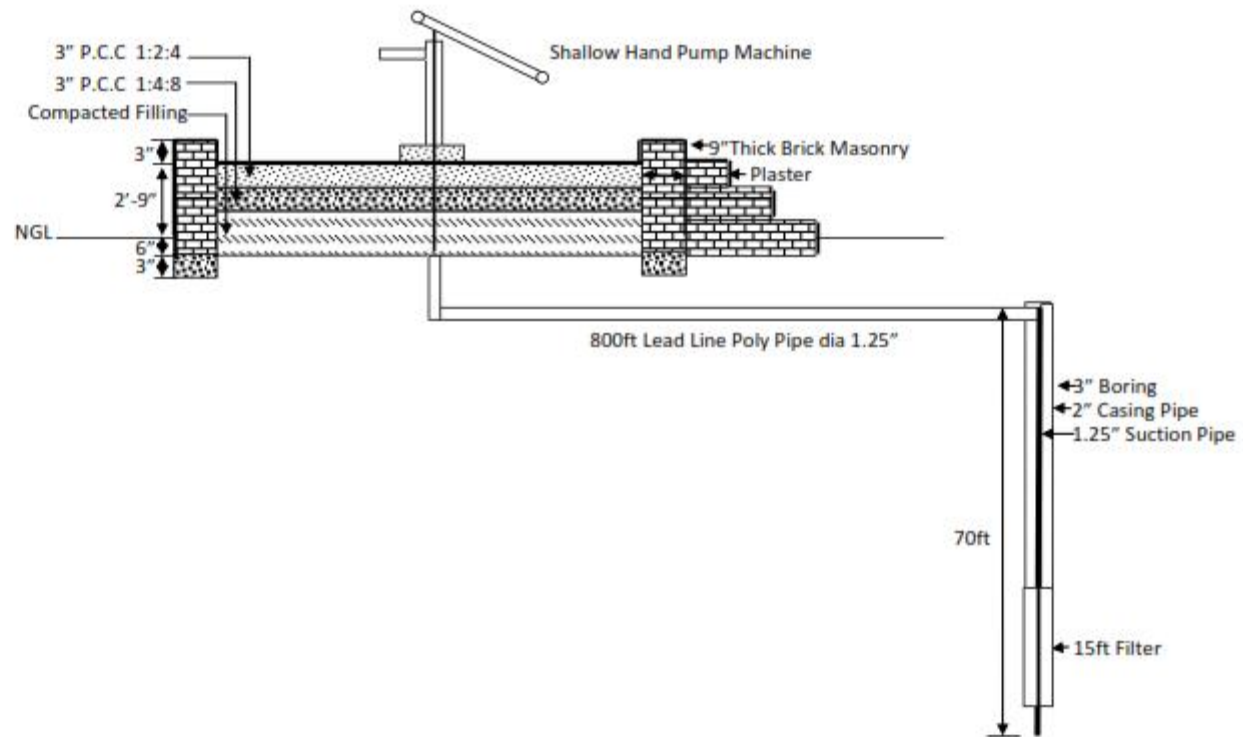

Prepared by:
 Mohsin Ali Qureshi
 Project Engineer-RDF

Drawing # 02
 Cross-section of Lead Line Hand
 Pump Raised Plate Form



Layout Plan of Direct Hand Pump with Plate Form (Size 5ft x 4ft x 2ft)

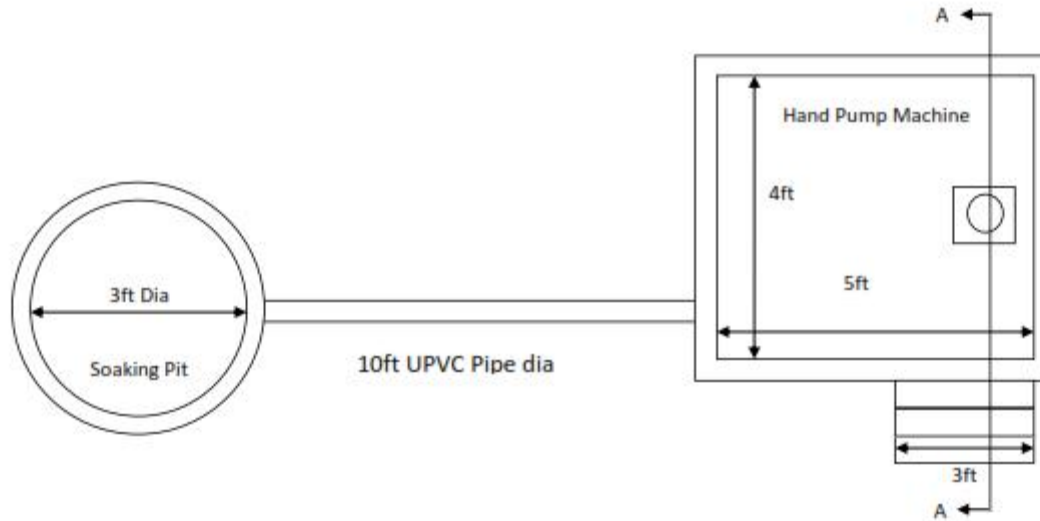

Prepared by:
Mohsin Ali Qureshi
Project Engineer-RDF

Drawing # 01
Layout Plan of Hand Pump Plate
Form



Cross-section of Direct Hand Pump Plate Form

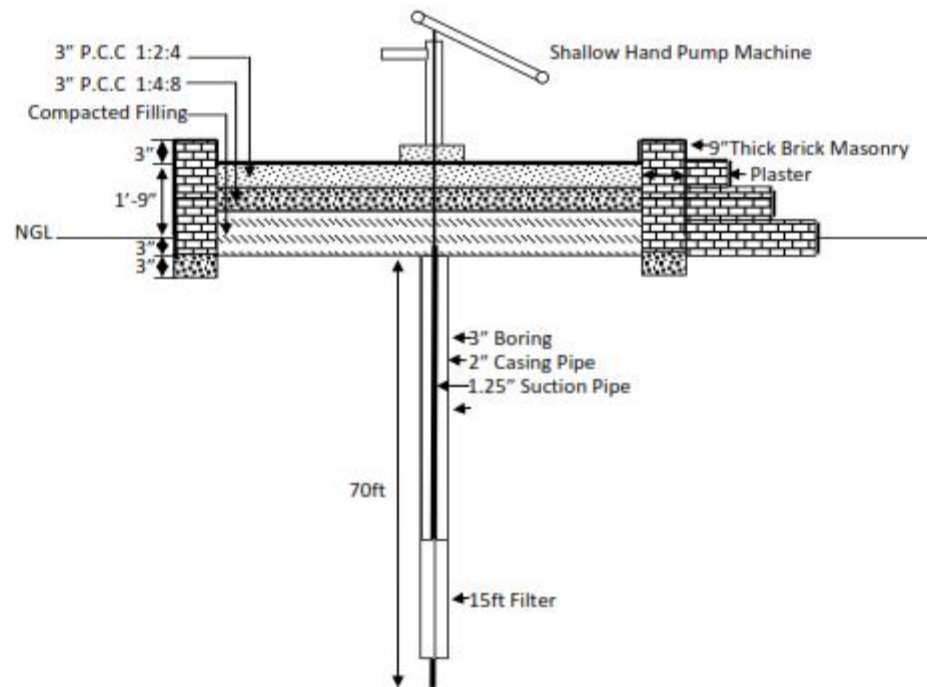

Prepared by:
Mohsin Ali Qureshi
Project Engineer-RDF

Drawing # 02
Cross-section of Hand Pump Plate
Form



Layout Plan of Hand Pump Plate Form

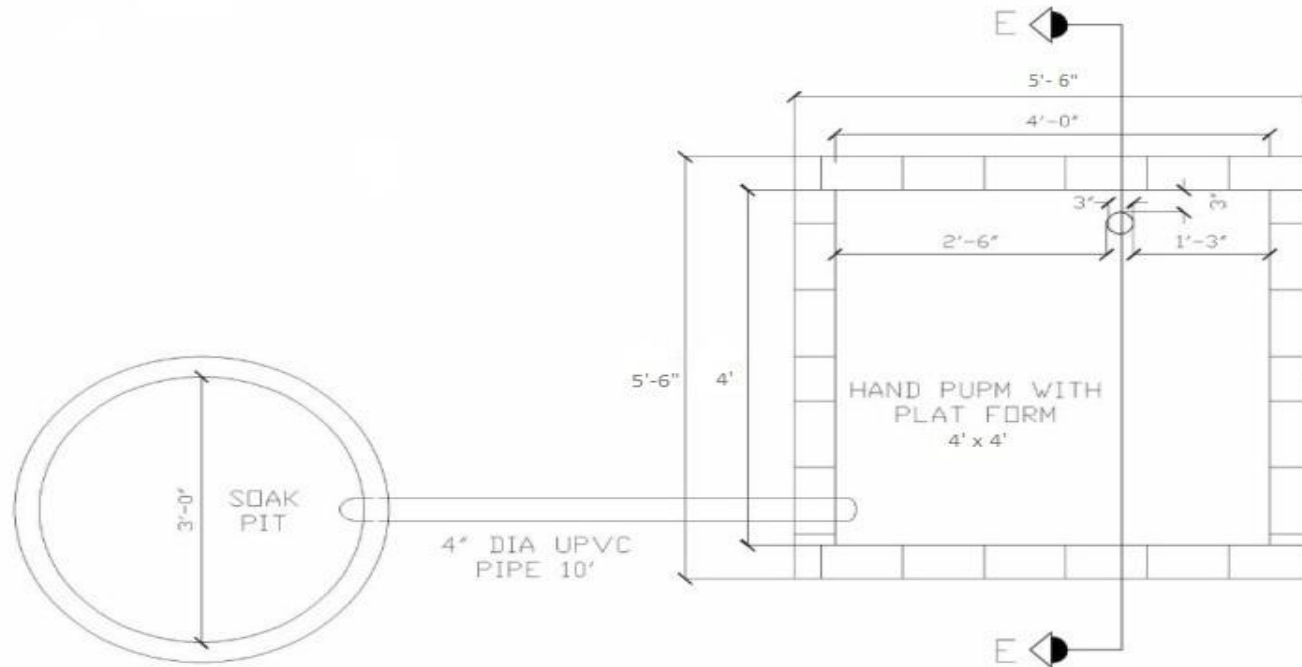

Plan of Hand Pump Plate Form

Prepared by: Mohsin Ali Qureshi
Senior Project Engineer-RDF

Drawing No. 01

Layout Plan of Dug Well

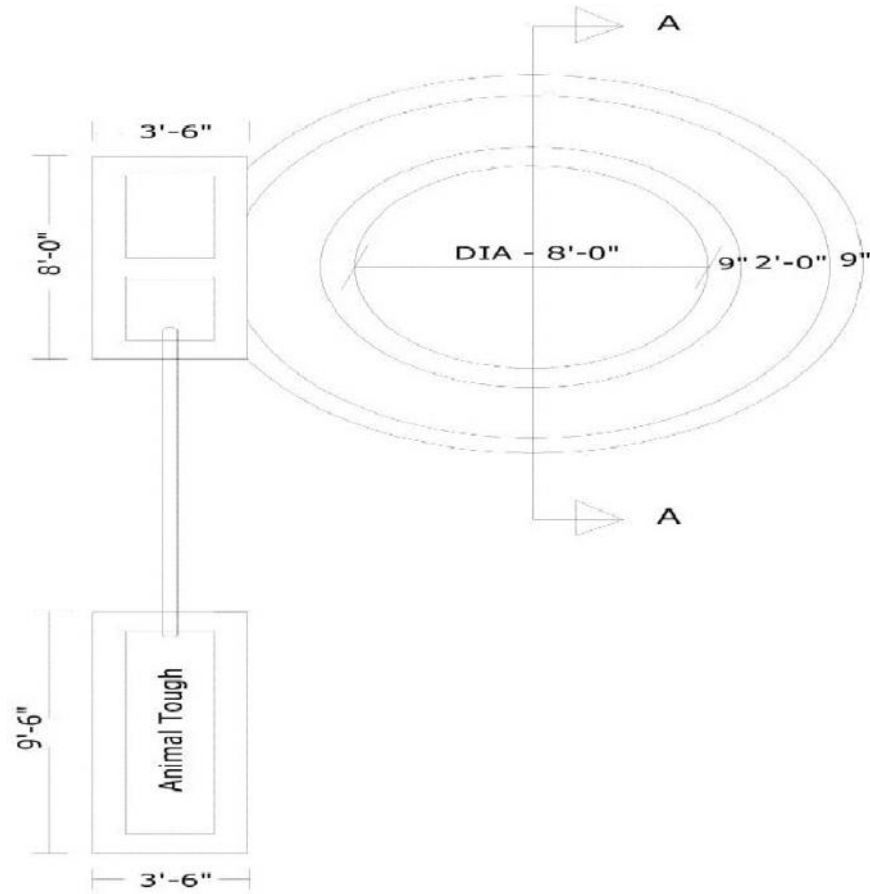

Plan of Dug Well

Prepared by: Mohsin Ali Qureshi
Senior Project Engineer-RDF

Drawing No. 01



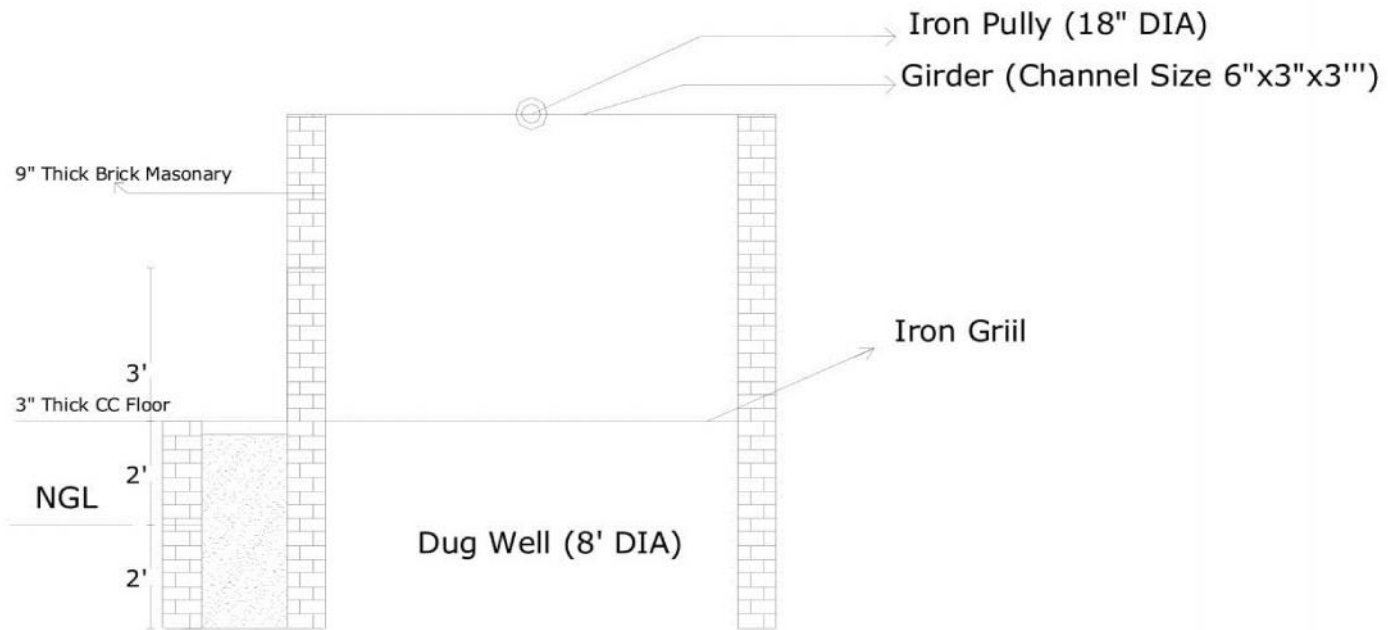

SECTION-AA



Section of Dug Well

Prepared by: Mohsin Ali Qureshi
Senior Project Engineer-RDF

Drawing No. 02



**Research and Development Foundation
Standard Model of Communal Rain Water Harvesting Tank (Locally called Tanka)**

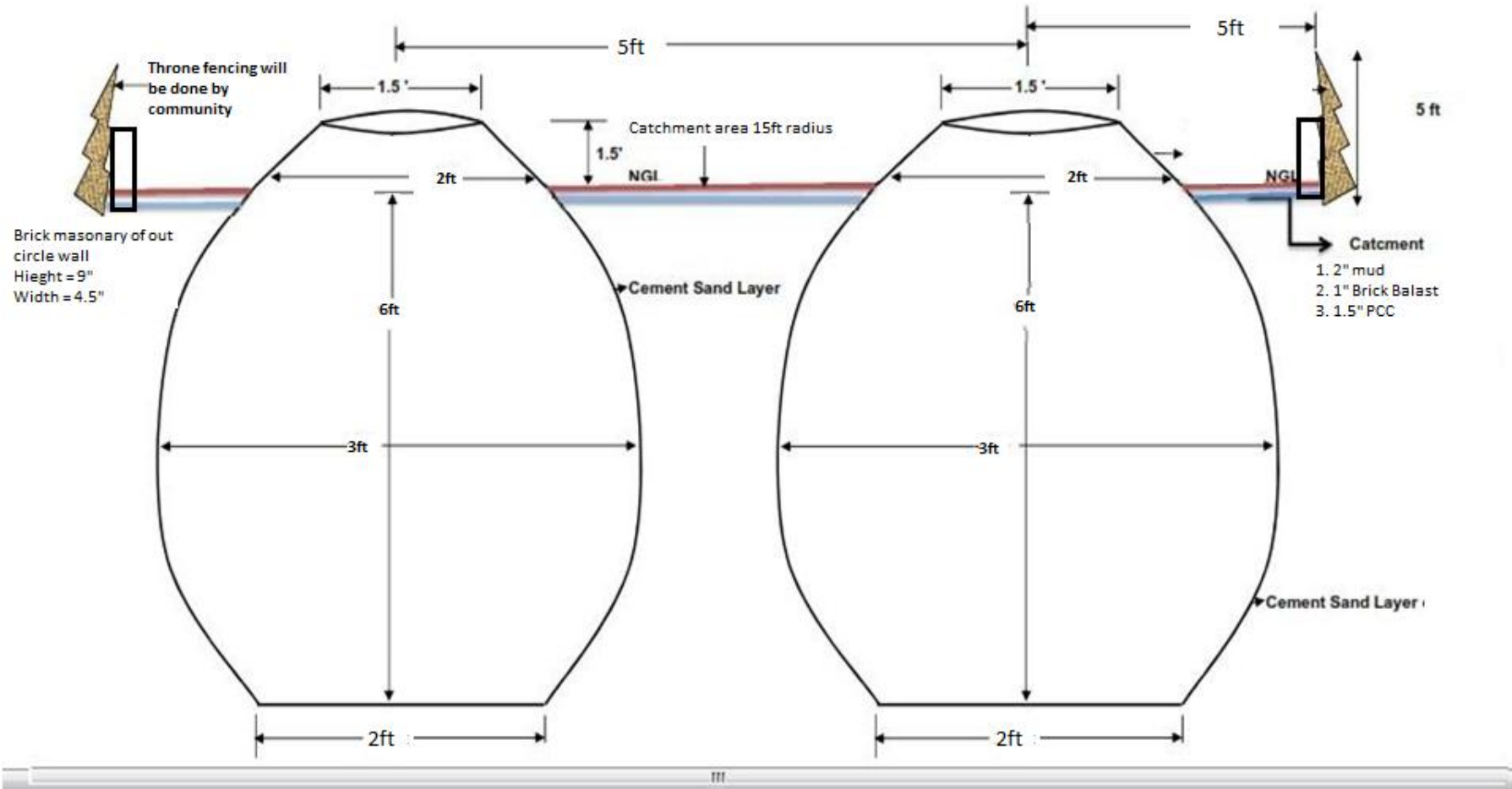

The Management structure: Procurement Committee is authorised to recommend for contract for approval by Executive Director. Contractor shall report to Project Manager at RDF field office District Sanghar and Thatta about material supply and construction work.

- **TIMING, LOGISTICS AND FACILITIES**

The Contract will commence within 10-15 day after evaluation of bids and sample analyses and period of implementation shall be **3-6 months**.

Contractor will be based at different field locations of district Sanghar and Thatta, Sindh for the duration of the task

No facilities will be provided by the Contracting Authority e.g. office accommodation

Contractor shall provide the services for supply and construction

- **REPORTING**

The contractor shall ensure the supply and construction after signing within the time period as per contract and inform the field staff in written correspondence about supply and construction

All delivered supplies and work done to be reported in written in English Language, contractor must bring 4 copies of delivery challans and have to submit 1 copy to community members where work done, 1 copy to RDF field staff, 1 copy to RDF Head Office and 1 copy for contractor

- **QUALIFICATION REQUIREMENTS**

1. **Technical Specification**

2. **Signed Tenderers Declaration**

3. **Company Certificate of Registration**

4. **Completed 'Tenderers Relevant Experience Form'**

5. **Samples. Please note that samples provided which do not meet the minimum specifications as per the attached tender dossier, will not qualify to the final tender evaluation process.**

6. **Valid Tax Registration**

7. **Recognized bank account (RDF) will make all payments through cross cheque or through bank transfers, and show financial soundness through bank statements.**

ANNEX 2: ORGANISATION AND METHODOLOGY

To be filled in by the Tenderers, in compliance with the following instructions:

Rationale

- Any comments on the Terms of Reference of importance for the successful execution of activities, in particular its objectives and expected results, thus demonstrating the degree of understanding of the Contract. Detailed list of inputs, activities and outputs. Any comments contradicting the Terms of Reference or falling outside their scope will not form part of the final Contract.
- An opinion on the key issues related to the achievement of the Contract objectives and expected results.
- An explanation of the risks and assumptions affecting the execution of the Contract.

Strategy

- An outline of the approach proposed for contract implementation.
- A list of the proposed activities considered to be necessary to achieve the contract objectives.
- A description of subcontracting arrangements foreseen, with a clear indication of the tasks that will be entrusted to a subcontractor and a statement by the Tenderer guaranteeing the eligibility of any subcontractor.

Timetable of activities

- The timing, sequence and duration of the proposed activities taking into account mobilisation time.
- Rehabilitation of Institutional WASH Facilities. The identification and timing of major milestones in execution of the Contract, including an indication of how the achievement of these would be reflected in any reports particularly those stipulated in the Terms of Reference.
- Include a programme.

Logical frame

- A Logical frame reflecting the considerations above.

Key Experts

- The Tenderer shall include a detailed description of the role and duties of each of the key experts or other non-key experts, which the Tenderer proposes to use for the performance of the services. The key experts are those whose involvement is considered instrumental in the achievement of the Contract objectives. In addition the Tenderer shall include information on current participation of key experts in other contracts and or commitments to participate in future contracts, including detailed description of their tasks and period of engagement.

ANNEX 3: TENDER SUBMISSION FORM

The financial proposal for the required services is as follows:

Description	Quantity	Currency	Amount
Lot# 1. Afridev Hand Pumps with Raised Plate Form (6ft x 5ft x 2ft)	20		
Lot# 2. Lead line Hand Pump with Raised Plate Form (Size 4ft X 5ft X 3ft).	60		
Lot# 3. Hand Pumps (Direct) with Raised Plate Form (4ft X 5ft x 1.75ft)	42		
Lot# 4. Major Repair Hand Pump with Plate Form (Size 4ft X 4ft).	70		
Lot# 5. Rehabilitation of Dug Wells.	06		
Lot# 6. Construction of Rain Water Harvesting Tanks (Locally Called Tanka) with Catchment.	110		
Lot# 7. Pour flush Latrine Single Unit.	3072		
Total price incl. Taxes			

Other relevant information:

TENDERER INFORMATION	
Company (legal name)	
Street name and no.	
City	
Postal code	
Country	
Phone no.	
Email	
Website	
Director (name)	

GENERAL COMPANY INFORMATION	
Year of establishment	
Number of full time employees	
Licensing authority	
Licence number (VAT no./TAX id)	
Countries with registered office:	
International quality assurance certification held by your company	
Local and national quality assurance certification held by your company	
International trade / professional organisations of which your company is a member	
Local trade / professional organisations of which your company is a member	
Does your company have CSR related policies in place – e.g. Health, Safety, HR, Energy or Climate policy or is a member of Global Compact? Please state which policies.	
Does your company live up to e.g. ISO	

26000/50001/14000 standards or is SA8000 certified? Please state which.	
Does your company have a Code of Conduct?	

REFERENCES				
Name and country of customer	Type of contract	Value	Contact name	Phone/fax and email

Please include details of the experience and past performance on contracts of a similar nature within the past five years and information on other contracts in hand and/or future commitments including details of the actual and effective participation in each of such contracts, description of the Tenderers assignments and periods of engagement. Additional documents can be attached to the above form.

The tender proposal is valid for period of 90 days after the closing date in accordance with the article A.9. validity, where as the contract may be signed for the required time period for implementation of work till 1 year or above.

After having read your Tender Dossier no. 3 for Material Supply and Construction Work dated 5th August 2016, and after having examined the Tender Dossier, I/we hereby offer to execute and complete the services in conformity with all conditions in the Tender Dossier for the sum indicated in our financial proposal.

On behalf of the company I/we hereby:

- Accept, without restrictions, all the provisions in the Tender Dossier including the General Terms and Conditions for Service Contracts - Ver2 2012 and the Draft Service Contract including all annexes.
- Provided that a contract is issued by the Contracting Authority I/we hereby commit to perform all services described in the Terms of Reference, Annex 1 within the time frame described in our Organisation and Methodology Form.
- Certify and attest compliance with eligibility criteria of article 33 of the General Terms and Conditions for Service - Ver2 2012.
- Certify and attest compliance with the Code of Conduct for Contractors in Annex 5.

The above declarations will become an integrated part of the Contract and misrepresentation will be regarded as grounds for termination.

Signature and stamp:

Signed by:

The Tenderer

Name of the company:

Address:

Telephone no.:

Email:

Name of contact person:

ANNEX 4: GENERAL TERMS AND CONDITIONS FOR SERVICE CONTRACTS – VER2 2012

1. DEFINITIONS

In these general terms and conditions:

- a) "contract" is the agreement entered into by the Contracting Authority and the Contractor for the performance of the services described in the terms of reference, to which these general terms and conditions are made applicable; the contract is constituted of the documents listed in the Service Contract.
- b) The Contracting Authority's "partners" are the organisations to which the Contracting Authority is associated or linked;
- c) "personnel" is any person assigned by the Contractor to the performance of the services or any part hereof, whether through employment, sub-contracting or any other agreement; and "key experts" are those members of the personnel whose involvement is considered instrumental in the achievement of the contract objectives;
- d) "beneficiary country" is the country where the services are to be performed, or where the project to which the services relate is located.

2. RELATIONS BETWEEN THE PARTIES

Nothing contained in the contract shall be construed as establishing a relation of master and servant or of agent and principal as between the Contracting Authority and the Contractor. Except if otherwise provided in the contract, the Contractor shall under no circumstances act as the representative of the Contracting Authority or give the impression that the Contractor has been given such authority. The Contractor has complete charge of the personnel and shall be fully responsible for the services performed by them.

3. SCOPE OF SERVICES

The scope of the services including the methods and means to be used by the Contractor, the results to be achieved by him and the verifiable indicators are specified in the Terms of Reference. The Contractor shall be responsible for everything which is required for the performance of the services in accordance with what is specified in the contract, or which must otherwise be regarded as forming part of the services.

4. COMPLIANCE WITH LAWS AND RESPECT OF TRADITIONS

The Contractor shall respect and abide by all laws and regulations in force in the beneficiary country and shall ensure that its personnel, their dependants, and its local employees also respect and abide by all such laws and regulations. The Contractor shall indemnify the Contracting Authority against any claims and proceedings arising from any infringement by the Contractor, its personnel and their dependants of such laws and regulations.

The Contractor, its personnel and their dependants shall respect human rights and undertake not to offend the political, cultural and religious practices prevailing in the beneficiary country.

5. CODE OF CONDUCT

The Contractor shall at all times act loyally and impartially and as a faithful adviser to the Contracting Authority and shall perform the services with due care, efficiency and diligence, in accordance with the best professional practice.

6. DISCRETION AND CONFIDENTIALITY

The Contractor shall treat all documents and information received in connection with the contract as private and confidential, and shall not, save in so far as may be necessary for the purposes of the performance thereof, publish or disclose any particulars of the contract without the prior consent in writing of the Contracting Authority. It shall, in particular, refrain from making any public statements concerning the project or the services without the prior approval of the Contracting Authority,

7. CONFLICT OF INTEREST

The Contractor shall refrain from engaging in any activity which conflicts with his obligations towards the Contracting Authority under the contract.

The Contractor shall take all necessary measures to prevent or end any situation that could compromise the impartial and objective performance of the Contract. Such conflict of interests could arise in particular as a result of economic interest, political or national affinity, family or emotional ties, or any other relevant connection or shared interest. Any conflict of interests which could arise during performance of the Contract must be notified in writing to the Contracting Authority without delay. The Contractor shall replace, immediately and without compensation from the Contracting Authority, any member of its personnel exposed to such a situation.

8. CORRUPT PRACTICES

The Contractor and the personnel shall refrain from performing, condoning or tolerating any corrupt, fraudulent, collusive or coercive

practices, whether such practices are in relation with the performance of the contract or not. "Corrupt practice" means the offering, giving, receiving, or soliciting, directly or indirectly, of anything of value as an inducement or reward for doing or forbearing to do any act in relation to the contract or any other contract with the Contracting Authority, or for showing favour or disfavour to any person in relation to the contract or any other contract with the Contracting Authority.

The payments to the Contractor under the contract shall constitute the only income or benefit it may derive in connection with the contract and neither it nor its personnel shall accept any commission, discount, allowance, indirect payment or other consideration in connection with, or in relation to, or in discharge of, its obligations under the contract.

The execution of the contract shall not give rise to unusual commercial expenses. Unusual commercial expenses are commissions not mentioned in the contract or not stemming from a properly concluded contract referring to the contract, commissions not paid in return for any actual and legitimate service, commissions remitted to a tax haven, commissions paid to a recipient who is not clearly identified or commission paid to a company which has every appearance of being a front company.

The Contractor further warrants that no official of the Contracting Authority and/or their partner has received or will be offered by the Contractor any direct or indirect benefit arising from this Contract.

9. JOINT VENTURE OR CONSORTIUM

If the Contractor is a joint venture or a consortium of two or more legal persons, all such persons shall be jointly and severally bound to fulfil the terms of the contract. The person designated by the joint venture or consortium to act on its behalf for the purposes of this contract shall have the authority to bind the joint venture or consortium.

For the purposes of performance of the contract, the joint venture or consortium shall act as, and be considered, a single person and, in particular, shall have bank account opened in its name, shall submit to the Contracting Authority single guarantees if required, and shall submit single invoices and single reports.

The composition of the joint venture or a consortium shall not be altered without the prior written consent of the Contracting Authority.

10. SPECIFICATIONS AND DESIGNS

The Contractor shall prepare all specifications and designs using accepted and generally recognised systems acceptable to the Contracting Authority and taking into account the latest design criteria.

11. INFORMATION

The Contractor shall furnish the Contracting Authority or any person authorised by the Contracting Authority with any information relating to the services and the project as the Contracting Authority may at any time request.

12. REPORTS

The frequency, deadlines, format and contents of the reports to be drawn up by the Contractor in relation to the performance of the contract shall be described in the Terms of Reference.

13. CONTRACTOR'S PERSONNEL

13.1. The Contractor shall employ and provide such qualified and experienced personnel as are required to carry out the services, and the Contractor shall be responsible for the quality of the personnel.

The carrying out of the services of each of the personnel and key experts are described in the Organisation and Methodology part of the contract. The Contractor must inform the Contracting Authority of all non-expert personnel it intends to use for the implementation of the contract. The Contracting Authority shall have the right to oppose the Contractor's choice of personnel.

13.2. No changes shall be made in the personnel without the prior consent of the Contracting Authority. The Contractor shall provide a replacement with at least equivalent qualifications and experience and acceptable to the Contracting Authority if:

- a) on account of death, sickness or accident, a member of the Personnel is unable to continue providing his services,
- b) any member of the personnel is found by the Contracting Authority to be incompetent in discharging or unsuitable for the performance of his duties under the Contract,

c) for any reasons beyond the control of the Contractor, it becomes necessary to replace any member of the Personnel.

The request for replacement must be made in writing and state the reasons therefore. The Contractor shall proceed swiftly with the request and propose a replacement with at least equivalent qualifications and experience. The remuneration to be paid to the replacement cannot exceed that received by the replaced member of the personnel.

Failure by the Contractor to propose a replacement for a key expert satisfactory to the Contracting Authority, shall give the right to the Contracting Authority to terminate the contract.

Additional costs arising out of a replacement shall be borne by the Contractor.

13.3. Working hours

The days and hours of work of the Contractor or/and its personnel in the beneficiary country shall be fixed on the basis of the laws, regulations and customs of the beneficiary country and the requirements of the services.

13.4. Leave entitlement

Any taking of holiday leave by the personnel during the period of implementation of the contract must be at a time approved by the Contracting Authority.

Overtime, sick leave pay and holidays leave pay are deemed to be covered by the Contractor's remuneration.

14. SUB-CONTRACTING

Except from the subcontractors listed in the contract, the Consultant shall not subcontract to nor engage another independent contractor to perform any part of the services without the prior written consent of the Contracting Authority. Subcontractors must satisfy the eligibility criteria applicable for the award of the contract.

The Contracting Authority shall have no contractual relations with the subcontractors. The provisions of the contract, including these general terms and conditions, and in particular article 13.2 shall, where practicable, apply to the subcontractors and their personnel.

15. LIABILITY

At its own expense, the Contractor shall indemnify, protect and defend, the Contracting Authority, its agents and employees, from and against all actions, claims, losses or damages arising from any act or omission by the Contractor in the performance of the services, including any violation of any legal provisions, or rights of third parties, in respect of patents, trademarks and other forms of intellectual property such as copyrights.

Approval by the Contracting Authority of the Contractor's reports and issue of Completion Certificate shall not relieve the Contractor of its liability and shall not prevent the Contracting Authority from claiming damages.

The Contractor shall remain liable for any breach of its obligations under the contract for such period after the services have been performed as may be determined by the law governing the contract (the "liability period"). This time limit does not however apply when the damage arises from gross negligence or wilful misconduct of the Contractor.

During the liability period, or as soon as practicable after its expiration, the Contractor shall, at its expense, upon instruction of the Contracting Authority, remedy any deficiencies in the performance of the services. In case of default on the part of the Contractor to carry out such instructions, the Contracting Authority shall be entitled to hire another contractor to carry out the same, at the Contractor's expense.

16. INSURANCE

Within 20 days of signing the contract, the Contractor shall take out and maintain, at its own cost, a full indemnity insurance policy covering its professional liability under the contract and article 15 above, from the commencement date and until the end of the liability period.

Within 20 days of signing the contract, the Contractor shall take out and maintain a full indemnity insurance policy for a sum up to the higher of the maximum amount foreseen by the legislation of the country of the Contracting Authority and the amount foreseen by the legislation of the country in which the Contractor has its headquarters and covering, during the period of implementation of the contract, the following risks:

- a) loss of or damage to property purchased with funds provided under the contract, or produced by the Contractor;
- b) loss or damage to equipment, material and office facilities made available to the Contractor by the Contracting Authority;
- c) civil liability for accidents caused to third parties arising out of acts performed by the Contractor, its personnel and their dependents;
- d) employer's liability and workers' compensation in respect of the personnel as well as sickness, accident or death affecting the personnel and their dependents, including the cost of repatriation on health grounds;
- e) such other insurance as required by the laws in force in the beneficiary country.

Prior to the commencement date, the Contractor shall provide evidence to the Contracting Authority that the above insurances have been effected. During execution of the contract, the Contractor shall, when required, provide the Contracting Authority with copies of the insurance policies and the receipts for payment of premiums.

17. INTELLECTUAL AND INDUSTRIAL PROPERTY RIGHTS

All reports and data such as maps, diagrams, drawings, specifications, plans, statistics, calculations, databases, software and supporting records or materials acquired, compiled or prepared by the Contractor in the performance of the contract shall, with the copyright thereto, be the absolute property of the Contracting Authority. The Contractor shall, upon completion of the contract, deliver all such documents and data to the Contracting Authority. The Contractor may not retain copies of such documents and data and shall not use them for purposes unrelated to the contract without the prior written consent of the Contracting Authority.

The Contractor shall not publish articles relating to the services or refer to them when carrying out any services for others, or divulge information obtained from the Contracting Authority, without the prior written consent of the Contracting Authority.

18. RECORDS

The Contractor shall keep separate, accurate and systematic records and accounts in respect of the services in such form and detail as is customary in the profession and sufficient to establish accurately that the number of working days and the actual reimbursable expenditure identified in the Contractor's invoice(s) have been duly incurred for the performance of the services.

For a fee-based contract, timesheets recording the days worked by the Contractor's personnel must be maintained by the Contractor. The timesheets must be approved by the Contracting Authority or any person authorised by the Contracting Authority or the Contracting Authority itself on a monthly basis. The amounts invoiced by the Contractor must correspond to these timesheets. In the case of long-term experts, these timesheets must record the number of days worked. In the case of short-term experts, these timesheets must record the number of hours worked. Time spent travelling exclusively and necessarily for the purpose of the Contract may be included in the numbers of days or hours, as appropriate, recorded in these timesheets.

Such records must be kept for a 7-year period after the final payment made under the contract. These documents comprise any documentation concerning income and expenditure and any inventory, necessary for the checking of supporting documents, including timesheets, plane and transport tickets, pay slips for the remuneration paid to the experts and invoices or receipts for reimbursable expenditure. Failure to maintain such records constitutes a breach of contract and will result in the termination of the contract.

19. OBLIGATIONS OF CONTRACTING AUTHORITY

19.1. The Contracting Authority shall provide the Contractor as soon as possible with any information and/or documentation at its disposal which may be relevant to the performance of the contract.

On all matters properly referred to it in writing by the Contractor, the Contracting Authority shall give its decisions so as not to delay the services, and within a reasonable time.

19.2. The contract shall specify whether the Contracting Authority is to provide the Contractor with equipment, facilities, counterpart personnel or specific assistance, and shall detail under which conditions. If the provision of such agreed counterpart personnel, equipment, facilities and assistance is delayed or not forthcoming, the Contractor shall endeavour to perform the Services as far as is possible. The parties shall agree on how the affected parts of the services shall be carried

out, and the additional payments, if any is due, to be made by the Contracting Authority to the Contractor as a result of additional expenditures.

20. CONTRACT PRICE AND PAYMENTS

Contracts are either "global price" or "fee-based".

20.1. Fee-based contract

In consideration of the services performed by the Contractor under the contract, the Contracting Authority shall make to the Contractor such payments of fees and such reimbursement of costs as provided in the contract.

Fees shall be determined on the basis of time actually spent by the key experts in the performance of services at the fee rates specified in the contract. Fee rates are deemed to remunerate all the activities of the Contractor in the performance of the services and to cover all expenses and costs incurred by the Contractor which are not included in the agreed reimbursable costs.

The Contracting Authority shall reimburse to the Contractor the reimbursable costs and expenses specified in the contract, actually and reasonably incurred in the performance of the services.

Costs and expenses which are not mentioned in the contract shall be deemed covered by the overhead of profit included in the fees.

The currency of payments of fees and reimbursable costs and applicable exchange rates are set out in the contract.

20.2. Global price contract

The global price covers both the Contractor's and its personnel's fees and all expenses to be incurred for the performance of the contract. The global price is in consideration for all obligations of the Contractor under the contract and all matters and things necessary for the proper execution and completion of the services and the remedying of any deficiencies therein.

20.3. Revision

Unless otherwise stipulated in the contract, the global price of a global price contract and the fee rates of a fee-based contract shall not be revised.

20.4. Guarantees

In the case an advance payment for fees and for reimbursable costs (fee-based contract) or a pre-financing payment (global price contract) is agreed in the contract, its payment by the Contracting Authority shall be subject to the prior presentation by the Contractor to the Contracting Authority of an approved performance security, advance payment or pre-financing guarantee, if so agreed and under the conditions specified in the Service Contract.

20.5. Conditions of Payment

Payments will be made by the Contracting Authority with the frequency, instalments, time limits, amounts and currencies, and under the conditions, in particular on the contents of invoices, specified in the special conditions of the contract. Payment of the final balance shall be subject to performance by the Contractor of all its obligations under the contract and the issue by the Contracting Authority of the completion certificate described in article 25.

20.6. Late payment

If the time periods laid down for payments by the Contracting Authority have been exceeded by more than two months and where the Contracting Authority cannot invoke a case of suspension or withholding of payments provided for in these terms and conditions, the Contractor may claim interest calculated on any amount due, prorata on the number of days of delay at the official bank rate of the beneficiary country (if amounts due are in the currency of that country), or at the rate applied by the European central bank (where amounts due are in Euro), plus 2% per year.

21. DELAYS IN PERFORMANCE

If the Contractor does not perform the services within the period of implementation specified in the contract, the Contracting Authority shall, without formal notice and without prejudice to its other remedies under the contract, be entitled to liquidated damages for every day, or part thereof, which shall elapse between the end of the period of implementation specified in the contract and the actual end of the period of implementation.

The daily rate for liquidated damages is calculated by dividing the contract value by the number of days of the period of implementation.

If these liquidated damages exceed more than 15% of the contract value, the Contracting Authority may, after giving notice to the Contractor:

- a) terminate the contract; and
- b) complete the services at the Contractor's own expense

22. BREACH OF CONTRACT

Either party commits a breach of contract where it fails to discharge any of its obligations under the contract.

Where a breach of contract occurs, the party injured by the breach shall be entitled to the following remedies:

- a) liquidated damages; and/or
- b) termination of the contract.

In any case where the Contracting Authority is entitled to damages, it may deduct such damages from any sums due to the Contractor or call on the appropriate guarantee.

The Contracting Authority shall be entitled to compensation for any damage which comes to light after the contract is completed in accordance with the law governing the contract.

23. SUSPENSION OF PERFORMANCE

The Contractor shall, on the request of the Contracting Authority, suspend the performance of the services or any part thereof for such time and in such manner as the Contracting Authority may consider necessary.

In such event of suspension, the Contractor shall take immediate action to reduce the costs incident to the suspension to a minimum. During the period of suspension, and except where the suspension is due to any default of the Contractor, the Contractor shall be reimbursed for additional costs reasonably and necessarily incurred by it as a result of the suspension.

24. AMENDMENT OF THE CONTRACT

Substantial modifications to the contract, including modifications to the total contract amount, must be made by means of an addendum.

25. COMPLETION CERTIFICATE

Upon completion of the services, and once (a) the Contracting Authority has approved the Contractor's completion report, (b) the Contracting Authority has approved the Contractor's final invoice and final audited statement, the Contracting Authority shall deliver a completion certificate to the Contractor.

26. TERMINATION BY THE CONTRACTING AUTHORITY

26.1 The Contracting Authority may terminate the contract after giving a 7 days' notice to the Contractor in any of the following cases:

- a) the Contractor is in breach of its obligations under the contract and/or fails to carry out the services substantially in accordance with the contract;
- b) the Contractor fails to comply within a reasonable time with the notice given by the Contracting Authority requiring it to make good the neglect or failure to perform its obligations under the contract which seriously affects the proper and timely performance of the services;
- c) the Contractor refuses or neglects to carry out instructions given by the Contracting Authority;
- d) the Contractor's declarations in respect of its eligibility (article 33) and/or in respect of article 31 and article 32, appear to have been untrue, or cease to be true;
- e) the Contractor takes some action without requesting or obtaining the prior consent of the Contracting Authority in any case where such consent is required under the contract;
- f) any of the key experts is no longer available, and the Contractor fails to propose a replacement satisfactory to the Contracting Authority;
- g) any organisational modification occurs involving a change in the legal personality, nature or control of the Contractor or the joint venture or consortium, unless such modification is recorded in an addendum to the contract;
- h) the Contractor fails to provide the required guarantees or insurance, or the person providing the underlying guarantee or insurance is not able to abide by its commitments.

26.2 Termination by Contracting Authority for convenience

The Contracting Authority may terminate the contract in whole or in part for its convenience, upon not less than 14 days' notice. The Contracting Authority shall not use this right of termination in order to arrange for the

services to be executed by another contractor, or to avoid a termination of the contract by the Contractor.

27. TERMINATION BY THE CONTRACTOR

The Contractor may terminate the contract after giving a 7 days' notice to the Contracting Authority in any of the following cases:

- a) the Contractor has not received payment of that part of any invoice which is not contested by the Contracting Authority, within 90 days of the due payment date,
- b) the period of suspension of the performance of the contract under article 23 has exceeded six months;
- c) the Contracting Authority is in material breach of its obligations under the Contract and has not taken any actions to remedy the same within 30 days following the receipt by the Contracting Authority of the Contractor's notice specifying such breach.

If the Contractor is a natural person, the contract shall be automatically terminated if that person dies.

28. RIGHTS AND OBLIGATIONS UPON TERMINATION

28.1. Upon termination of the contract by notice of either party to the other, the Contractor shall take immediate steps to bring the services to a close in a prompt and orderly manner and in such a way as to keep costs to a minimum.

28.2. If the Contracting Authority terminates the contract in accordance with article 26.1 it may, thereafter, complete the services itself, or conclude any other contract with a third party, at the Contractor's expense.

The Contracting Authority shall, as soon as is possible after termination, certify the value of the services and all sums due to the Contractor as at the date of termination. It shall, subject to article 28.1 and 28.3, make the following payments to the Contractor:

- (a) remuneration pursuant to the contract for services satisfactorily performed prior to the effective date of termination;
- (b) reimbursable costs (if fee-based contract) for costs actually incurred prior to the effective date of termination;
- (c) except in the case of termination pursuant to article 26.1 reimbursement of any reasonable cost incident to the prompt and orderly termination of the contract;
- (d) in case of termination under article 26.2 and 27, reimbursement for the actual and reasonable costs incurred by the Contractor as a direct result of such termination and which could not be avoided or reduced by appropriate mitigation measures.
The Contractor shall not be entitled to claim, in addition to the above sums, compensation for any loss or injury suffered.

28.3. In case of termination of the contract for any reason whatsoever, any pre-financing guarantee which might have been granted to the Contracting Authority under article 20.4, may be invoked forthwith by the Contracting Authority in order to repay any balance still owed to the Contracting Authority by the Contractor, and the guarantor shall not delay payment or raise objection for any reason whatever.

28.4. If the Contracting Authority terminates the contract under article 26.1, it shall be entitled to recover from the Contractor any loss it has suffered up to that part of the contract value which corresponds to that part of the services which has not, by reason of the Contractor's default, been satisfactorily completed.

29. FORCE MAJEURE

Neither party shall be considered to be in breach of its obligations under the contract if the performance of such obligations is prevented by any circumstances of force majeure which arise after the date of signature of the contract by both parties.

The term "force majeure", as used herein shall mean acts of God, strikes, lock-outs or other industrial disturbances, acts of the public enemy, wars, whether declared or not, blockades, insurrection, riots, epidemics, landslides, earthquakes, storms, lightning, floods, washouts, civil disturbances, explosions, and any other similar unforeseeable events, beyond the control of either party and which by the exercise of due diligence neither party is able to overcome.

A party affected by an event of force majeure shall take all reasonable measures to remove such party's inability to fulfil its obligations hereunder with a minimum of delay.

If either party considers that any circumstances of force majeure have occurred which may affect performance of its obligations it shall notify

the other party immediately giving details of the nature, the probable duration and likely effect of the circumstances. Unless otherwise directed by the Contracting Authority in writing, the Contractor shall continue to perform its obligations under the contract as far as is reasonably practicable, and shall seek all reasonable alternative means for performance of its obligations which are not prevented by the force majeure event. The Contractor shall not put into effect such alternative means unless directed so to do by the Contracting Authority.

30. APPLICABLE LAW AND DISPUTES

The contract is governed by, and shall be construed in accordance with the laws of the Contracting Authority's country.

Any dispute or breach of contract arising under this contract shall be solved amicably if at all possible. If not possible and unless provided in the Service Contract, it shall be settled finally by court decision, which shall be held under the law of the Contracting Authority's country. Any ruling by the court will be final and directly executable in the country of the Contractor.

31. CHILD LABOUR AND FORCED LABOUR

The Contractor (and each member of a joint venture or a consortium) warrants that it and its affiliates comply with the UN *Convention on the Rights of the Child* - UNGA Doc A/RES/44/25 (12 December 1989) with Annex – and that it or its affiliates has not made or will not make use of forced or compulsory labour as described in the *Forced Labour Convention* and in the *Abolition of Forced Labour Convention 105* of the International Labour Organization. Furthermore the Contractor warrants that it, and its affiliates, respect and uphold basic social rights and working conditions for its employees. Any breach of this representation and warranty, in the past or during the performance of the contract, shall entitle the Contracting Authority to terminate this contract immediately upon notice to the Contractor, at no cost or liability for the Contracting Authority.

32. MINES

The Contractor and each member of the joint venture or a consortium) warrants that it and its affiliates is NOT engaged in any development, sale or manufacture of anti-personnel mines and/or cluster bombs or components utilized in the manufacture of anti-personnel mines and/or cluster bombs. Any breach of this representation and warranty shall entitle the Contracting Authority to terminate this contract immediately upon notice to the Contractor, at no cost or liability for the Contracting Authority.

33. INELIGIBILITY

By signing the purchase order, the Contractor (or, if a joint venture or a consortium, any member thereof) certifies that they are NOT in one of the situations listed below:

- (a) They are bankrupt or being wound up, are having their affairs administrated by courts, have entered into an agreement with creditors, have suspended business activities, are the subject of proceedings concerning house matters, or are in any analogous situation arising from a similar procedure provided for in national legislation or regulations;
- (b) They have been convicted of an offence concerning their professional conduct by a judgement that has the force of *res judicata*;
- (c) They have been guilty of grave professional misconduct proven by any means that the Contracting Authority can justify;
- (d) They have not fulfilled obligations relating to the payment of social security contributions or payment of taxes in accordance with the legal provisions of the country in which they are established or with those of the country of the Contracting Authority or those of the country where the contract is to be performed;
- (e) They have been the subject of a judgement that has the force of *res judicata* for fraud, corruption, involvement in a criminal organisation or any other illegal activity detrimental to the Contracting Authority or the European Communities financial interests;
- (f) Following another procurement procedure or grant award procedure financed by the European Community budget or following another procurement procedure carried out by the Contracting Authority or one of their partners, they have been declared to be in serious breach of contract for failure to comply with their contractual obligations.

34. CHECKS AND AUDITS

The Contractor shall permit the Contracting Authority or its representative to inspect, at any time, records including financial and

accounting documents and to make copies thereof and shall permit the Contracting Authority or any person authorized by it, including the European Commission, the European Anti-Fraud Office and the Court of Auditors in case the contract is financed by the European Community budget, at any time, to have access to its financial accounting documents and to audit such records and accounts both during and after the provision of the services. In particular, it may carry out

whatever documentary or on-the-spot checks it deems necessary to find evidence in case of suspected unusual commercial expenses.

35. LIABILITY

Under no circumstances or for no reason whatsoever will the Back donor entertain any request for indemnity or payment directly submitted by the (Contracting Authority's) contractors.

ANNEX 5: CODE OF CONDUCT FOR CONTRACTORS



CODE OF CONDUCT FOR CONTRACTORS

ETHICAL PRINCIPLES AND STANDARDS

By this Code of Conduct, the Contracting Authority applies ethics to procurement. We expect our contractors to act socially and environmentally responsible and actively work for the implementation of the standards and principles in this Code of Conduct. The Code of Conduct is applicable for all our contractors who supply goods, services and works to our operations and projects.

This Code of Conduct and its related principles and standards are based on recommendations from the Danish Initiative for Ethical Trade (DIEH)¹, the UN Global Compact principles² and ECHO's Humanitarian Aid Guidelines for Procurement 2011³.

General Conditions

The Code of Conduct defines the ethical requirements and standards for our contractors, whom we expect to sign and respect the Code of Conduct, and work actively towards the implementation hereof. By signing the Code of Conduct contractors agree to place ethics central to their business activities.

The provision of the ethical standards constitutes minimum rather than maximum standards. International and national laws shall be complied with, and where the provisions of law and the Contracting Authority's standards address the same subject, the highest standard shall apply. It is the responsibility of the contractor to assure that their contractors and subcontractors comply with the ethical requirements and standards set forth in this Code of Conduct.

The Contracting Authority acknowledge that implementing ethical standards and ensuring ethical behaviour in our supply chain is a continuous process and a long term commitment for which we also have a responsibility. In order to achieve high ethical standards for procurement we are willing to engage in dialogue and collaboration with our contractors. In addition we expect our contractors to be open and willing to engage in dialogue with us to implement ethical standards for their businesses.

Unwillingness to co-operate or serious violations of the Code of Conduct will lead to termination of contracts.

Human Rights and Labour Rights

Contractors must at all times protect and promote human- and labour rights and work actively to address issues of concern. As a minimum they are obliged to comply with the following ethical standards:

- **Respect for Human Rights** (UN Universal Declaration of Human Rights)
The basic principles of the Universal Human Rights are that all human beings are born free and equal in dignity and in rights, and everyone has the right to life, liberty and security of the person. Contractors must not flaunt their responsibility to uphold and promote the Human Rights toward employees and the community in which they operate.
- **Non exploitation of Child Labour** (UN Child Convention on the Rights of the Child, and ILO Convention C138 & C182)
Contractors must not engage in the exploitation of child labour⁴ and contractors must take the necessary steps to prevent the employment of child labour. A child is defined as a person under the age of 18 and children shall not be engaged in labour that compromise their health, safety, mental and social development, and schooling. Children under the age of 15 (in developing

countries 14) may not be engaged in regular work, but children above the age of 13 (in developing countries 12) can be engaged in light work if it does not interfere with compulsory schooling and is not harmful to their health and development.

- **Employment is freely chosen** (ILO Convention C29 & C105)
Contractors must not make use of forced or bonded labour and must respect workers freedom to leave their employer.
- **Freedom of association and the right to collective bargaining** (ILO Convention C87 & C98)
Contractors must recognise workers right to join or form trade unions and bargain collectively, and should adopt an open attitude towards the activities of trade unions (even if this is restricted under national law).
- **Living wages are paid** (ILO convention C131)
As a minimum, national minimum wage standards or ILO wage standards must be met by contractors. Additionally a living wage must be provided. A living wage is contextual, but must always meet basic needs such as food, shelter, clothing, health care and schooling and provide a discretionary income⁵ - which is not always the case with a formal minimum wage.
- **No discrimination in employment** (ILO Convention C100 & C111 and the UN Convention on Discrimination against Women)
Contractors must not practice discrimination in hiring, salaries, job termination, retiring, and access to training or promotion - based on race, national origin, caste, gender, sexual orientation, political affiliation, disability, marital status, or HIV/AIDS status.
- **No harsh or inhumane treatment of employees** (ILO Convention C105)
The use of physical abuse, disciplinary punishment, sexual abuse, the threat of sexual and physical abuse, and other forms of intimidation may never be practiced by contractors.
- **Working conditions are safe and hygienic** (ILO Convention C155)
Contractors must take adequate steps to provide safe and hygienic working environments. Additionally workers safety must be a priority and adequate steps must be taken to prevent accidents and injury to health associated with or occurring in the course of work.
- **Working hours are not excessive** (ILO Convention C1 & C14)
Contractors must ensure that working hours comply with national law and international standards. A working week of 7 days should not exceed 48 hours and employees must have one day off per week. Overtime shall be compensated, limited and voluntary.
- **Regular employment is provided** (ILO Convention C143)
All Work performed must be on the basis of a recognised employment relationship established through international conventions and national law. Contractors must protect vulnerable group's regular employment under these laws and conventions and must provide workers with a written contract.

International Humanitarian Law

Contractors linked to armed conflicts or operating in armed conflict settings shall respect civilian's rights under International Humanitarian Law and not be engaged in activities which directly or indirectly initiate, sustain, and/or exacerbate armed conflicts and violations of

¹ <http://www.dieh.dk/etisk-handel/hvordan-etisk-handel/dieh-retningslinjer-for-etisk-handel/dieh-guidelines/>

² <http://www.unglobalcompact.org/AboutTheGC/TheTenPrinciples/index.html>

³ http://ec.europa.eu/echo/partners/humanitarian_aid/procurement_guidelines_en.htm

⁴ The definition of Child Labour can be found at: <http://www.unglobalcompact.org/AboutTheGC/TheTenPrinciples/principle5.html> and <http://www.ilo.org/ilolex/cgi-lex/convdv.pl?C138>

⁵ Discretionary income is the amount of an individual's income that is left for spending, investing, or saving after taxes and personal necessities (such as food, shelter, and clothing) have been paid.

International Humanitarian Law⁶. Contractors are expected to take a 'do no harm' approach to people affected by armed conflict.

Additionally, Contractors shall not be engaged in any other illegal activity.

Involvement in Weapon Activities

The Contracting Authority advocates for the Ottawa Convention against landmines and the Convention on Cluster Munitions against cluster bombs. Contractors shall not engage in any development, distribution, sale, or manufacturing of anti-personnel mines, cluster bombs, components, or any other weapon which feed into violations of International Humanitarian Law and Human Rights.

Protection of the Environment

The Contracting Authority wishes to minimise the environmental damages applied to nature via our procurement activities and we expect our suppliers and contractors to act in an environmentally responsible manner. This involves respecting applicable national and international environmental legislation and acting in accordance with the Rio Declaration.

As a minimum contractors should address issues related to proper waste management, ensuring recycling, conservation of scarce resources, and efficient energy use.

Anti-Corruption

Corruption is by the Contracting Authority defined as the misuse of entrusted power for private gain and it includes bribery, fraud, embezzlement and extortion. The Contracting Authority holds a great responsibility to avoid corruption and ensure high standards of integrity, accountability, fairness and professional conduct in our business relations. Contractors are expected to have the same approach by undertaking good and fair business ethics and practices, take action to prevent and fight corruption, and abide by international conventions as well as international and national laws. To fight corruption and promote transparency, contractors who are confronted with corrupt practices are advised to file a complaint in a Complaint Mechanism⁷.

A contractor's involvement in any form of corrupt practice during any stage of a selection process, in relation to the performance of a contract or in any other business context is unacceptable and will lead to the rejection of bids or termination of contracts.

List of International Conventions and Treaties covered by this Code of Conduct for Contractors

- UN Universal Declaration of Human Rights, 1948; <http://www.un.org/en/documents/udhr/index.shtml>
- Un Guiding Principles on Business and Human Rights, 2011; http://www.ohchr.org/Documents/Publications/GuidingPrinciplesBusinessHR_EN.pdf
- Geneva Conventions I-IV, 1949 and additional Protocols; <http://www.icrc.org/eng/war-and-law/treaties-customary-law/geneva-conventions/index.jsp>
- ILO Declaration on Fundamental Principles and Rights at Work, 1998; <http://www.ilo.org/declaration/lang--en/index.htm> and http://www.ilo.org/wcmsp5/groups/public/---ed_norm/---declaration/documents/publication/wcms_095898.pdf
- UN Child Convention on the Rights of the Child, 1990; <http://www2.ohchr.org/english/law/crc.htm>
- C182, Worst Forms of Child Labour Convention, 1999; <http://www.ilo.org/ilolex/cgi-lex/convde.pl?C182>
- C138, Minimum Age Convention, 1973; <http://www.ilo.org/ilolex/cgi-lex/convde.pl?C138>

- C87, Freedom of Association and Protection of the Right to Organise Convention, 1948; <http://www.ilo.org/ilolex/cgi-lex/convde.pl?C087>
- C98, Right to Organise and Collective Bargaining Convention, 1949; <http://www.ilo.org/ilolex/cgi-lex/convde.pl?C098>
- C29, Forced Labour Convention, 1930; <http://www.ilo.org/ilolex/cgi-lex/convde.pl?C029>
- C105, Abolition of Forced Labour Convention, 1957; <http://www.ilo.org/ilolex/cgi-lex/convde.pl?C105>
- C131, Minimum Wage Fixing Convention, 1970; <http://www.ilo.org/ilolex/cgi-lex/convde.pl?C131>
- C100, Equal Remuneration Convention, 1951; <http://www.ilo.org/ilolex/cgi-lex/convde.pl?C100>
- C111, Discrimination (Employment and Occupation) Convention, 1958; <http://www.ilo.org/ilolex/cgi-lex/convde.pl?C111>
- The UN Convention on the Elimination on All Forms of Discrimination against Women 1979; <http://www.un.org/womenwatch/daw/cedaw/text/econvention.htm>
- C1, Hours of Work (Industry) Convention, 1919; <http://www.ilo.org/ilolex/cgi-lex/convde.pl?C001>
- C14, Weekly Rest (Industry) Convention, 1921; <http://www.ilo.org/ilolex/cgi-lex/convde.pl?C014>
- C143, Migrant Workers (Supplementary Provisions) convention, 1975; <http://www.ilo.org/ilolex/cgi-lex/convde.pl?C143>
- C155, Occupational Safety and Health Convention, 1981; <http://www.ilo.org/ilolex/cgi-lex/convde.pl?C155>
- The Rio Declaration on Environment and Development, 1992; <http://www.unep.org/Documents.Multilingual/Default.asp?DocumentID=78&ArticleID=1163&I=en>
- The Ottawa Convention, 1997; http://www.apminebanconvention.org/fileadmin/pdf/mbc/text_status/Ottawa_Convention_English.pdf
- The Convention on Cluster Munitions, 2007; <http://www.clusterconvention.org/files/2011/01/Convention-ENG1.pdf>
- Arms Trade Treaty, 2013; <http://www.un.org/disarmament/ATT/>

⁶ This includes pillage/looting which is the unlawful taking of private property for personal or private gain based on force, threats, intimidation, pressure and through a position of power accomplished due to the surrounding conflict.

⁷ Contractors who have signed a contract with DCA, or DCA implementing partner, shall file a complaint through: <http://www.danchurchaid.org/about-us/quality-assurance/anti-corruption/complaints>