



Tender Notice



Reference: [RDF/NCA-Telethon/02/11-03-2018/01](#)

Item number and title: 1, 2, 3,4,5,6 and 7

Contracting Authority: Research and Development Foundation

Deadline for submission of offer: **2nd April 2018** at 05:00 pm.

INVITATION TO BID

Research & Development Foundation (RDF) is a non-profit, non-government organization, currently working in District Sanghar and Thatta, Sindh with the assistance from NCA for Strengthen community resilience to floods, and improve access to safe drinking water, adequate sanitation and hygiene in District Thatta and Sanghar, Sindh Province. Research and Development Foundation is launching a "Local Open Tender" and invites sealed tenders from interested registered suppliers/vendors/ contractors/ candidates to participate in the procurement procedure for the relevant lot(s): for the supply of following items; construction material and construction Work:

S.No	Description	Specification required	Total Quantity
1	Construction of Communal Rain Water Harvesting Tanks	Detail in Tender Pack	75
2	Rehabilitation of dug wells	Detail in Tender Pack	13
3	Installation of New Handpumps with Leadlines and Raised Platform	Detail in Tender Pack	50
4	Installation of Afridev Handpumps	Detail in Tender Pack	15
5	Installation of Direct Borehole Handpump with Raised Platform	Detail in Tender Pack	40
6	Rehabilitation of Existing Dysfunctional Handpumps	Detail in Tender Pack	50
7	Construction of Pour Flush Latrines with Bathing Facilities	Detail in Tender Pack	350

Terms and Conditions;

1. All the goods are for a humanitarian project in District Sanghar and Thatta District, Sindh, an intervention supported by NCA.
2. All goods are to be delivered at different field locations of District Sanghar and Thatta, Sindh, Pakistan.
3. The offered prices shall be quoted in PKR only.
4. Lowest price will not be the sole criteria. Quality, previous experience and timely delivery will also be considered.
5. All offers, in English language only, must be delivered to the office mentioned below by



05:00 pm, on **02ndApril2018**. Late bids will be rejected. Applicants with questions regarding this tender should send them in writing (fax or email) up to 05:00 pm **23rd March2018**.

6. Tenders will be opened at the address mentioned below at the time stated in the Tender Dossier. Tenderers or their authorized representative can be present at the opening of tenders.
7. The successful tenderer shall place a 10% Performance Guarantee upon signing of the Contract. 1% call deposit must be submitted along with bid / tender documents.
8. Samples of each item must be submitted on or before **02ndApril2018** along with submission of tender document 1 day before tender opening. Non submission of samples might make the bidder ineligible/unqualified.
9. Tender documents will be available from **11thMarch2018** to **02ndApril2018** in office timing till 09:00 am – 05:00 pm from Monday to Friday. Interested tenderers may obtain the Tender Dossier in English.

Research and Development Foundation

House# A-50, Sindhi Muslim Cooperative Housing Society
Qasimabad, Hyderabad.

Contact Person: Asad Ali Chandio- Procurement Officer

Telephone Number: 022-2102702-3

Email Address: achandio@rdfoundation.org.pk

Website: www.rdfoundation.org.pk

Tender Dossier may also be downloaded from RDF website www.rdfoundation.org.pk

OR

By sending email at below mentioned email address.

INVITATION TO TENDER

TO:

Date of issue:	11 th March 2018
Tender no.:	RDF/NCA-Telethon/02/11-03-2018/01
Contract title:	Supply of Construction Material and Construction Work (Civil Work).
Closing date:	02 nd April 2018 at 05:00pm
Tender opening:	03 rd April 2018 at 10:30 am
Contracting Authority:	Research and Development Foundation. House# A-50, Sindhi Muslim Cooperative Housing Society Qasimabad, Hyderabad Contact person: Asad Ali Chandio Tel: 022-2102702-3 Fax: 0222102704 Email: achandio@rdfoundation.org.pk

RESEARCH AND DEVELOPMENT FOUNDATION INVITES YOU TO TENDER FOR: SUPPLY OF CONSTRUCTION MATERIAL AND CONSTRUCTION WORK (CIVIL WORK)

Dear Sir/Madam,

The Services are required for Strengthen community resilience to floods, and improve access to safe drinking water, adequate sanitation and hygiene in Sanghar and Thatta districts, Sindh Province, an intervention supported by NCA.

Please find enclosed the following documents, which constitute the Tender Dossier:

- A – Instructions to Tenderers
- B – Draft Contract including Annexes:
 - Annex 1: Terms of Reference
 - Annex 2: Organisation and Methodology (to be completed by the Tenderer)
 - Annex 3: Tender Submission Form (to be completed by the Tenderer)
 - Annex 4: General Terms and Conditions for Service Contracts – Ver2 2012
 - Annex 5: Code of Conduct for Contractors

If this document is in PDF format, upon request a complete copy of the above documents can be forwarded in WORD format for electronic completion. It is forbidden to make alterations in the text.

We would be grateful if you would inform us by email of your intention to submit or not submit a proposal.

A. INSTRUCTIONS TO TENDERERS

In submitting a proposal the Tenderer accepts in full and without restriction the special and general conditions including annexes governing this Contract as the sole basis of this procedure, whatever his/her own conditions of services may be, which the Tenderer hereby waives. The Tenderers are expected to examine carefully and comply with all instructions, forms, contract provisions and specifications contained in this Tender Dossier.

A.1. Scope of services

The Services required by the Contracting Authority are described in the Terms of Reference in Annex 1. The Tenderer shall offer the totality of the Services described in the Terms of Reference. Tenderers offering only part of the required Services will be rejected.

A.2. Cost of participating in tender process

The Tenderer shall bear all costs associated with the preparation and submission of his/her proposal and the Contracting Authority is not responsible or liable for these costs, regardless of the conduct or outcome of the process.

A.3. Clarification of tender documents and additional information

Tenderers may submit questions in writing at the latest on the date specified in the timetable in article A.4, specifying the tender no., and the contract title. Information regarding interpretation of this invitation to tender must be requested in writing to the Contracting Authority's contact person.

Tenderers are not allowed to approach the Contracting Authority for verbal clarification.

Any clarification of the Tender Dossier given by the Contracting Authority will be submitted to all tenderers at the latest on the date specified in the timetable. If the Contracting Authority provides additional information on the tender dossier, such information will be sent in writing to all other prospective tenderers at the same time.

Any prospective tenderer seeking to arrange individual meetings during the tender period with either the Contracting Authority and/or any other organisation with which the Contracting Authority is associated or linked may be excluded from the tender procedure.

A.4. Planned timetable

The Contracting Authority reserves the right to alter the dates and times in the following timetable, in which case all tenderers will be informed in writing and a new timetable will be provided.

	Date	Time
Deadline for request for any clarifications from the Contracting Authority	23 rd March 2018 Friday	05:00pm
Last date on which clarifications are issued by the Contracting Authority	31 st March 2018 Saturday	05:00Pm
Deadline for submission of tenders (closing date)	02 nd April 2018	05:00 pm
Tender opening session	03 rd April 2018	10:30am
Contract award	06 th April 2018	03:00pm
Contract start	09 th April 2018	

All times are in the time zone of Pakistan.

A.5. Eligibility and qualification requirements

Tenderers are not eligible to participate in the tender procedure if they are in one of the situations listed in article 33 of the General Terms and Conditions for Service Contracts – Ver2 2012.

Tenderers shall in the Tender Submission Form attest that they meet the above eligibility criteria. If required by the Contracting Authority, the Tenderer whose tender is accepted shall further provide evidence satisfactory to the Contracting Authority of its eligibility through certificates issued by competent authorities in its country of establishment or operation, or, if such certificates are not available, through a sworn statement.

Tenderers are also requested to certify that they comply with the Code of Conduct for Contractors, as well as to give evidence of their capability and adequate resources tenderers shall provide the information and the documents requested in the Tender Dossier.

A.6. Exclusion from award of contracts

Contracts may not be awarded to Tenderers who, during the procurement procedure:

- (a) are subject to conflict of interest; and/or
- (b) are guilty of misrepresentation in supplying the information required as a condition of participation and eligibility in the tender procedure or fail to supply this information.

A.7. Language of Tenders

The tenders, all correspondence and documents related to the Tender exchanged by the Tenderer and the Contracting Authority must be written in English.

A.8. Documents comprising the Tender

The Tenderer shall complete and submit the following documents with his/her tender:

- a) Tender Submission Form (Annex 3) with supporting documents and duly completed and signed by the Tenderer
- b) Organisation and Methodology using the structure in Annex 2
- c) CV highlighting the Tenderer's experience in the specific field of the Services and his/her specific experience in the country/region where the Services are to be performed;
- d) Copies of Tenderer's audited financial statement for the last three years.
- e) Evidence of any quality accreditation or ISO Certifications
- f) PEC Registration Certificate and FBR Registration Certificate and SRB
- g) Performance Guarantee
- h) Tender Guarantee

And other relevant information that should be made known to the Contracting Authority.

A.9. Tender Guarantee

All tenders must be accompanied by a Tender Guarantee of minimum 1% of the total tender amount. The guarantee shall be issued in favour of the Contracting Authority and be valid for 6 months beyond the period of validity of the Tender. The Tender Guarantee shall be issued in the form of a first demand guarantee, by an internationally recognised bank or other financial institution, and shall be in accordance with the text in the attached guarantee. The Tender Guarantee may also be issued in the form of a banker's draft, a certified cheque, a bond provided by an insurance company or an irrevocable letter of credit, as long as it creates under the applicable law the same irrevocable, at-first-demand obligations for the guarantor as expressed in the wording of the attached guarantee.

A.10. Financial proposal

The Financial Proposal shall be presented as an amount in PKR in the Tender Submission Form in Annex 3. The price proposed by the Tenderer shall not be subject to adjustments except as otherwise provided in the conditions of the Contract.

For evaluation purpose, where proposals are given in PKR, it shall be converted into EUR at the rate published in State Bank of Pakistan on the closing date.

The remuneration of the Contractor under the Contract shall be determined as follows:

A.11. Subcontractors

If the Tenderer intends to use subcontractors, the Tenderer shall state in the Organisation and Methodology, Annex 2, their names, qualifications, role and duties in the performance of the Contract and the Tenderer shall specify the parts of the Services which will be executed by the subcontractors, which may not exceed 30% of the Contract. Provisions of article "Tenderers proposed personnel" concerning the Tenderers personnel and the article concerning eligibility and qualification requirements shall apply to the subcontractors or the subcontractor's personnel.

A.12. Validity

Tenders shall remain valid and open for acceptance for 6 months after the closing date for the submission of tenders.

Prior to the expiry of the tender validity period, the Contracting Authority may ask tenderers in writing to extend this period. Tenderers that agree to do so will not be permitted to modify their tenders. If they refuse, their participation in the tender procedure will be terminated.

A.13. Submission of tenders and closing date

Tenders must be received at the address mentioned below by hand or post not later than the closing date and time specified in the time table article A.4. Any tenders received after that time will not be considered. Tenders shall be submitted in a sealed envelope bearing the following information:

Research and Development Foundation
House# A-50, Sindhi Muslim Cooperative Housing Society, Qasimabad, Hyderabad.

Attention: Procurement Section
Tender receipt: 02nd April 2018 at 05:00pm
Tender no.: RDF/NCA-Telethon/02/11-03-2018/01

All tenders must be submitted in one original, marked "original"
No tender may be changed or withdrawn after the deadline has passed.

A.14. Tender opening

Tenderers are invited to attend the tender opening. Tenderers are requested to advise the contact person, at least one day in advance of the tender opening if they will attend.

Tender opening will take place at RDF Head Office House# A-50, Sindhi Muslim Cooperative Housing Society Qasimabad, Hyderabad at the time and date specified in article A.4. Tenderers representatives who are present shall sign a register indicating their attendance.

At the tender opening, only the Tenderers names, the total amount of the tenders and any discount offered will be read aloud and recorded.

A.15. Evaluation of Tenders

Prior to the detailed evaluation of the tenders, the evaluation committee, (established by the Contracting Authority for the purposes of this tender procedure), shall ascertain whether the tenders meet the eligibility requirements; have been properly signed, are substantially responsive to the tender documents; have any material errors in computation; and are otherwise generally in order.

If a tender is not substantially responsive i.e. it contains material deviations from or reservations to the Terms of Reference and/or conditions in the tender dossier, it shall not be considered further.

After analysing the substantially responsive tenders, the evaluation committee will examine the technical admissibility of each tender, classifying it as technically compliant or non-compliant. Deviations from the Terms of Reference may be considered if deemed to be in the best interest of the Contracting Authority.

Tenders determined to be substantially responsive and technically compliant will be checked by the evaluation committee for any arithmetic errors. Where there is a discrepancy between the amounts in the figures and words, the amount in words will govern. If a Tenderer refuses to accept the correction, his/her tender will be rejected.

Evaluation method

The evaluation method will be the quality and cost based selection. A two-stage procedure shall be utilised in evaluating the tenders; a technical evaluation and a financial evaluation.

Tenders will be ranked according to their combined technical (St) and financial (Sf) scores using the weights of 75% for the technical proposal; and 25% for the offered price. Each tender's overall score shall therefore be: $St \times 75\% + Sf \times 25\%$.

Technical evaluation

For the evaluation of the technical proposals, the Contracting Authority shall take the following criteria into consideration, with the indicated weights:

Here are given two types of evaluation formats (A and B) and scoring format with a little change but the major points are coverable for both formats to check qualifying a tenderer. Contracting Authority may analyse technical evaluation by using any one sort of (A or B) below options.

A.

Technical evaluation		Maximum Points
Expertise of the Candidate submitting proposal		
1	Tenderers economic and financial capacity	4
2	Tenderers technical capacity	3
3	Extent to which any service would be sub-contracted	4
4	Availability of quality assurance procedures and quality accreditations	4
5	Organisation's specialised knowledge and experience in the field of assignment and selected region	3
6	Tenderers overall relevant academic qualifications	3
7	Tenderers overall relevant experience in the field of assignment	3
8	Tenderers experience in the region/country e.g. knowledge of local language, culture, administrative system, government etc.	3
9	Tenderers proficiency in English	3
10	Tenderers CSR related policies – e.g. HR policy, health and safety policy, energy policy, climate policy, Global Compact membership etc.	5
11	CSR related standards/certifications-e.g. ISO26000/50001/140000 or SA80000 certification	5
Sub-total individual Tenderer and/or Company		40
1	To what degree does the proposal show understanding of the task?	8
2	Have the Terms of Reference been addressed in sufficient detail?	8
3	Is the conceptual framework adopted appropriate for the task?	8
4	Is the sequence of activities and the planning logical, realistic and promising efficient implementation to the Contract?	8
5	Is the work plan adequate in responding to the Terms of Reference	8
Sub-total Organisation and Methodology		40
1	Key Expert 's relevant academic qualifications	-
2	Key Expert 's relevant experience in the field of assignment	10
3	Key Expert 's experience in the region/country e.g. knowledge of local language, culture, administrative system, government etc.	10
4	Key Expert 's proficiency in English language	-
Sub-total Key expert		20
Total Technical Score		100

B.

Technical evaluation	Maximum Points
NTN Registration No#	10
PEC Registration Certificate	10
Previous Experience	10
Economic Financial Capacity	5
Tenderers technical capacity	10
Audited Financial Statements	5
Quality Assurance	10
Delivery/ Completion Time Period	5
Bid Security	5
Sample Assessment	30
Total Technical Score	100

Financial evaluation

Each proposal shall be given a financial score. The lowest Financial Proposal (Fm) will be given a financial score (Sf) of 100 points. The formula for determining the financial scores shall be the following:

$Sf = 100 \times Fm/F$, in which

Sf is the financial score

Fm is the lowest price and

F is the price of the proposal under evaluation

A.16. Award Criteria

The Contracting Authority will award the contract to the Tenderer whose tender has been determined to be substantially responsive to the Tender Dossier and technically compliant, and who has obtained the highest overall score, provided further that the Tenderer has demonstrated the capability and resources to carry out the contract effectively.

A.17. Signature and entry into force of the Contract

Prior to the expiration of the tender validity period, the Contracting Authority will inform the successful Tenderer in writing that its tender has been accepted and inform the non-successful tenderers in writing about the result of the evaluation process.

The Contracting Authority reserves the right to adjust the services within a range of +/- 25% to remain within the available funds.

Within 7 days of receipt of the Contract, not yet signed by the Contracting Authority, the successful Tenderer must sign and date the Contract and return it with the Performance Guarantee to the Contracting Authority on signing the Contract, and subject to the provision of a valid Performance Guarantee, the successful Tenderer will become the Contractor and the Contract will enter into force once signed by the Contracting Authority.

If the successful Tenderer fails to sign and return the Contract and the Performance Guarantee within the days stipulated, the Contracting Authority may consider the acceptance of the Tender to be cancelled without prejudice to the Contracting Authority's right to seize the Tender Guarantee, claim compensation or pursue any other remedy in respect of such failure, and the successful Tenderer will have no claim whatsoever on the Contracting Authority.

A.18. Performance Guarantee

Within 7 days of receipt of the Contract from the Contracting Authority, the successful Tenderer shall, furnish a Performance Guarantee in accordance with Article B.16 of the Draft Contract.

A.19. Cancellation for convenience

The Contracting Authority may for its own convenience and without charge or liability cancel the tender process at any stage.

B. DRAFT CONTRACT (SERVICE)

CONTRACT TITLE: SUPPLY OF CONSTRUCTION MATERIAL, CONSTRUCTION WORK FOR WASH
ACTIVITIES

Contract no.: RDF/NCA-Telethon/02/11-03-2018/01

Instructions to tenderers: at this stage of the tender preparation this Draft Contract document is for your information and intended to make you aware of the contractual provisions. The information missing in this document will be filled in when a successful Tenderer has been selected, and the "Draft" Contract will then become the "final" Contract between the Contracting Authority and the Contractor

Research and Development Foundation
House# A-50, Sindhi Muslim Cooperative Housing Society
Qasimabad, Hyderabad

("The Contracting Authority"),
of the one part,

and

("the Contractor")
of the other part,

have agreed as stipulated in the attached document.

The Contract is done in English in three originals, two originals being for the Contracting Authority and one original being for the Contractor.

For the Contractor

For the Contracting Authority

Name:

Name:

Title:

Title:

Signature:

Signature:

Date:

Date:

Special Conditions

B.1. Scope of services

The subject of the Contract is Supplies and Constructions at different field locations of District Sanghar and Thatta, Sindh, Pakistan. The "Supplies and Services" are described in the Terms of Reference and further specified in the Organisation and Methodology.

The Contractor acknowledges that:

- a) The Contracting Authority is not obligated to place any minimum number of contract with the Contractor, pursuant to this Contract;
- b) The Contracting Authority shall not be liable for any cost in the event that no contract is placed under this Contract; and
- c) This Contract is nonexclusive, and the Contracting Authority is entitled to procure the same or similar services from other Contractors, as it sees fit.

B.2. Commencement Date and Period of Implementation

The Contract shall commence after signature of this Contract by both parties and on the date the Contractor provides to the Contracting Authority the Performance Guarantee. The period of implementation of the services is [] weeks from the commencement date.

B.3. Terms and Termination

The Contract is valid for a period of 6 months, and commences on the commencement date and expires at midnight on the expiry date, unless earlier termination in accordance with the General Terms and Conditions for Service – Ver2 2012 of this Contract.

The Contracting Authority shall be entitled to renegotiate the Contract for a further period of 6 months on similar terms and conditions, by giving the Contractor written notice of its intention to renegotiate the Contract not less than 15 days prior to the expiry date, provided however that in the event of a breach of the Agreement by one of the Parties, the other party may for valid cause terminate the Contract as per General Terms and Conditions for Service – Ver2 2012, article 26 and 27.

B.4. Delivery of Services & Supplies

The Contracting Authority will issue contracts to the Contractor, during the term of this Contract, marking reference to this Contract, and setting out the services required, the location and timing and other instructions for the delivery of Services.

The Contractor agrees to deliver Services to the Contracting Authority pursuant to the Contract, which shall conform to the Terms of References, Annex 1, Organisation and Methodology, Annex 2) and the price specified in this Contract.

In the event of the Contracting Authority placing a contract, which the Contractor considers it cannot substantially meet because of unavailability of staff or inability to meet the Terms of References, before proceeding to make a partial delivery of the services, the Contractor shall seek further written instructions from the Contracting Authority.

The Contractor shall cover all costs related to the remedy of an unacceptable Service.

The Contractor shall be responsible for providing all the necessary personnel, equipment, materials and supplies and for making all necessary arrangements for the performance of its obligations under this Contract.

B.5. Remuneration

VAT and/or any Withholding tax applicable to the purchase of services and supplies must be included in quoted rates where as SRB, SST / GST shall be indicated separately in the bids as well as in present Contract.

The Contractor guarantees that the price specified in this Contract, are the maximum price that shall remain firm and shall not be increased during the entire term of this Contract, provided however, that in the event that the Contractor is able to offer the Contracting Authority a discounted price on placement of bulk contracts, the unit price shall be reduced for specific contracts.

By signing this Contract, the Contractor certifies that the Contracting Authority, for transactions resulting from this Contract is not being charged more than other clients for similar services and within similar circumstances.

B.6. Reporting

The Contractor shall submit reports as specified in the Terms of Reference, Annex 1. The Contractor shall keep the Contracting Authority updated on contract progress on time to time.

B.7. Payment

Payments shall be made in PKR through cross cheque or by bank transfer to the following account: [if provided]

Account Number:

Name of Bank:

Address of Bank:

Account name:

Swift Code:

Payment will be made by the Contracting Authority within 20-30 days from approval by the Contracting Authority and receipt of the Contractor's invoice, Delivery Challans and Work Completion Certificates and inspection reports by field staff.

B.8. Tax and social contributions

The Contracting Authority shall have no obligation or responsibility in connection with taxes or levies payable by the Contractor in its country of establishment or in the beneficiary country in connection with its performance of this Contract.

This Contract is exempt from all duties and taxes, including VAT.

B.9. Liability

The Contractor will meet without limitation the liability obligations as stated in the General Terms and Conditions for Service Contracts Ver2 2012 article 15.

B.10. Order of precedence of contract documents

The Contract is made up of the following documents, in order of precedence:

1. This Contract
2. Terms of Reference (Annex 1)
3. Organisation and Methodology (Annex 2)
4. Tender Submission Form (Annex 3)
5. General Terms and Conditions for Service Contracts - Ver2 2012 (Annex 4)
6. Code of Conduct for Contractors (Annex 5)

The various documents making up the Contract shall be deemed to be mutually explanatory; in cases of ambiguity or divergence, they should be read in the order in which they appear above.

B.11. Language

The language of this contract and of all written communications between the Contractor and the Contracting Authority shall be English.

B.12. Entry into force and duration

The Contract shall enter into force and effect after signature by both parties of this Contract. The Contract shall remain into force and effect until the end of the liability period as defined in the General Terms and Conditions for Service Contracts - Ver2 2012.

B.13. Performance Guarantee

The Contractor shall, together with the return of the countersigned Contract, furnish the Contracting Authority with a guarantee for the full and proper execution of the Contract. The entry into force of the Contract shall be subject to the provision of the Performance Guarantee by the Contractor.

The amount of the guarantee shall be of 10% of the total contract amount and shall be denominated in the currency in which the Contract is payable, i.e. PKR.

The Performance Guarantee shall be held against payment to the Contracting Authority for any loss resulting from the Contractor's failure to perform his/her contractual obligations fully and properly.

The Performance Guarantee shall be issued in the form of a first demand guarantee, by an internationally recognised bank or other financial institution, and shall be in accordance with the text attached. The Performance Guarantee may also be issued in the form of a banker's draft, a certified cheque, a bond provided by an insurance company or an irrevocable letter of credit, as long as it creates under the applicable law the same irrevocable, at-first-demand obligations for the guarantor as expressed in the wording of the attached document.

The Contracting Authority shall demand payment from the guarantee of all sums for which the guarantor is liable under the guarantee due to the Contractor's default under the Contract, in accordance with the terms of the guarantee and up to the value thereof. The guarantor shall, without delay, pay those sums upon demand from the Contracting Authority and may not raise any objection for any reason whatsoever. Before making any claim under the Performance Guarantee, the Contracting Authority shall notify the Contractor stating the nature of the default in respect of which the claim is to be made.

The guarantee shall continue to remain valid until the Contract has been fully and properly performed.

The Contracting Authority shall, upon request, return the Performance Guarantee to the Contractor after completion of the Contract.

B.14. Notices

Any written communication relating to this Contract between the Contracting Authority and the Contractor must state the contract title and contract number, and must be sent by post, fax, e-mail or by hand to the addresses identified in this Contract.

B.15. General Terms and Conditions

The Contracting Authorities' General Terms and Conditions attached shall apply to this Contract and all contracts subsequently issued pursuant to this Contract.

- BACKGROUND INFORMATION

Research&DevelopmentFoundation(RDF)isanon-profit,non-governmentalorganization currently working in District Sanghar and Thatta with support of NCA-Telethonproject for Strengthen community resilience to floods, and improve access to safe drinking water, adequate sanitation and hygiene in Sanghar and Thatta districts, Sindh Province.

- CONTRACT PURPOSE AND EXPECTED RESULTS

1	Construction of Communal Rain Water Harvesting Tanks	75
2	Rehabilitation of dug wells	13
3	Installation of New Handpumps with Leadlines and Raised Platform	50
4	Installation of Afridev Handpumps	15
5	Installation of Direct Borehole Handpump with Raised Platform	40
6	Rehabilitation of Existing Dysfunctional Handpumps	50
7	Construction of Pour Flush Latrines with Bathing Facilities	350

- SCOPE OF THE SERVICES

This scope of assignment relates to the supply of construction materials and the construction (as per specification), but is not limited to transport up till the site of delivery i.e. District Sanghar and Thatta.

The tasks to be carried out by the Contractor

Lot# 01. (75 units)Construction of communal rain Water Harvesting Tanks (Tanka) Catchment (15ft Dia)

Type of Scheme:		75 units)Construction of Rain Water Harvesting Tanks (Tanka) with Catchment (15ft Dia)				
S.No	Item	Description	Qty.	Unit	Unit Rate (Rs:)	Amount (Rs:)
(A) Material						
1	Cement	Lucky or Pakland (OPC)	7	Bags		
2	Hill Sand	Fine sand bolhari	32	Cft		
3	Crush	1/2"- 3/4" dia stone	20	Cft		
4	Bricks	First class bricks (9" * 3" * 4.5")	185	Nos		
5	Iron Frame (Tanka Cover)	Iron Frame (1.5' X 1.5') with two panels smoke grey oil paint (approx weight 5kg)	2	Nos		
6	Steel Net	4"-dia circuler.	2	Nos		
7	U PVC Pipe 4" dia	4"dia pipe Al-jeddah/pak Al arab 9" length 4-pices.	2	Nos		
Total						
(B). Labour Charges						
1	Skilled	Cash for work	2	Days		
2	Unskilled	Cash for work	4	Days		
Total						
Total Cost A+B						

Note: Unit rate for all items to be quoted by supplier on company letter heads.

Lot# 02.Rehabilitation of Dug Wells (Solar Water Pump 08 Units) & (Major Repair 05 Units)

Type of Scheme:		Rehabilitation of Dug Wells (Solar Water Pump 08 Units) & (Major Repair 05 Units)				
S.No	Item	Description	Qty.	Unit	Unit Rate (Rs:)	Amount (Rs:)
1	Cement	Lucky/Pakland OPC	90	Bags		
2	Hill Sand	Fine sand bolari	865	Cft		
3	Bricks	First class bricks (9" * 3" * 4.5")	5840	No.s		
4	Fibre Tank	Master Fibre Glass Tank 500 Gallons	8	No.s		
5	Wooden Stand/ Block	Stand for Fibre Tank (size 1ftx 4ftx 1ft) 02 Nos	8	No.s		
6	Bib Cocks	Ilyas/Master Company	32	No.s		
7	Sanitry Fitting Material	4ft GI Pipe 1.5" dia welded 4 pipe niples 3/4" with sockets for bib cocks, end closer., 6 Elbow,01 PVC Handle Valve, 1.25" PVC Pipe 20 ft Solution TZ/AGM etc complete). 20 ft Nylon pipe 1"	8	No.s		
8	Solar Panels	Max Solar Panal 315 watt made by Germony	32	No.s		
9	Mounting Structure	Stand GI Sheet	32	No.s		
10	Submersible Water Pump	1HP Water Pump	8	No.s		
11	Controller Box	Control Panel including breakers & volt meter	8	No.s		
12	Electric Wire (Water Proof cable)	2 Core 4mm	400	m		
13	Suction Pipe	National PVC Pipe 1.25" dia (wt 48-50kg/500 rft)	1120	Rft		
14	Safety Rope	Iron rope dia 8 mm (including GI clips 48 No.s)	1200	Rft		
15	Girder	Girder Size 4" x 6" & 1.5kg/ft	80	Rft		
16	GI Rod	length 4ft & 1" dia including threads both sides, 04 bolts	5	No.s		
17	GI Pulley	GI Pully 6" dia, fixed bearing,fitted in GI Rod item No. 5	5	No.s		
18	Cotton Rope	Length 150 ft & 3/4 inch dia	750	Rft		
19	Construction & installation charges	Repair of well, chambers and water tank base with motor area	13	No.s		
Total						

Note: Unit rate for all items to be quoted by supplier on company letter heads.

Lot# 03.(50 unit) Installation of New Handpumps with Leadlines and Raised Platform

Type of Scheme:		Lead line Hand Pump with Raised Plate Form (Size 4ft X 5ft X 2.5ft)				
S.No	Item	Description	Qty.	Unit	Unit Rate (Rs:)	Amount (Rs:)
1	Bricks	First class bricks (9" * 3" * 4.5")	752	No.s		
2	Cement	Lucky/Pakland OPC	5	Bags		
3	Sand	Fine sand bolari	37	Cft		
4	Crush	Size (1/2"- 3/4") dia stone	16	Cft		
5	Gravel/Stone Ballast	Size (2"-2.5") Round Gravel	18	Cft		
6	UPVC-Pipe	4"dia Pipe jeddah/pak Al arab	12	Rft		
7	Drilling Bore	2.5" dia manually	60	Rft		
8	Casing Pipe	UPVC Pipe 2" dia jeddah/pak Al arab	60	Rft		
9	Suction Pipe	1.25" dia National PVC Pipe (wt 48-50kg/500 rft)	50	Rft		
10	Filter /Jali	UPVC with Colth Filter	1	No.s		
11	Elbow	UPVC 4" dia	2	No.s		
12	Steel Jali	Size 6" dia	1	No.s		
13	Hand Pump Machine (IILL - 2.5"dia)	6ft Long machine including 1ft brass cylinder (weight of cylinder is 1.5kg) with all brass accessories (Handle & stand #6 bar)	1	No.s		
14	Check wall	1.5" dia Brass (Khalil Company)	1	No.s		
15	Lead Line Pipe	1" Dia National PVC Pipe (wt 48-50kg/500 rft)	1000	Rft		
16	Lead line Fitting Material	GI Elbow, PVC Elbow, Valve Socket, Solution TZ/AGM etc complete)	1	No.s		
17	Lead line excavation & fitting	Excavation size (9" x 24") Labour work	1000	Rft		
18	Construction Charges (Plate Form)	Labour charges per unit	1	No.s		
Total						

Note: Unit rate for all items to be quoted by supplier on company letter heads.

Lot# 04. (15) Installation of Afridev Handpumps

Type of Scheme:		Afridev Hand Pumps, Raised Plate Form (6ft x 5ft x 2ft)				
S.No	Item	Description	Qty.	Unit	Unit Rate (Rs.)	Amount (Rs.)
1	Bricks	First class bricks (9" * 3" * 4.5")	1139.00	No.s		
2	Cement	Lucky or Pakland	10.00	Bags		
3	Sand	Fine Sand	64.00	Cft		
4	Crush	Size 1/2"- 3/4" dia	29.00	Cft		
5	Gravel (Shouting)	Size as per need	60.00	Cft		
6	Drilling Bore	Drilling 6" dia through manually	120.00	Rft		
7	Casing Pipe	Pressure Pipe C-Class 4" dia (Prince/Classic Company)	120.00	Rft		
8	Filter	Pressure Pipe C-Class 4" dia (Prince/Classic Company)	10.00	Rft		
9	Suction Pipe	Pressure Pipe C-Class 2" dia (Prince/Classic Company)	70.00	Rft		
10	GI Rod	Dia 12mm	70.00	Rft		
11	GI Rod Seals	Rubber Paking Seals	7.00	No.s		
12	Cone Seal	Rubber Paking Seals	1.00	No.s		
13	Wire Rope	Steel Rope	70.00	Rft		
14	UPVC-Pipe	4" dia Pipe Jeddah/Pak Al arab	22.00	Rft		
15	Elbow	4" dia UPVC Jeddah/Pak Al arab	2.00	No.s		
16	Steel Jali	6" dia (Circular)	1.00	No.s		
17	Afridev Hand Pump Machine with stand	Indus Company	1.00	No.s		
18	Nut & Bolt Set	Size (1.5" & 2") dia 5/8"	1.00	No.s		
19	Solution	TZ/AGM 450gm	2.00	No.s		
20	End Plug	UPVC Dia 2"	1.00	No.s		
21	Maintanance Kit	(Fishing rod 01 No.s, Cone seal 01 No.s, Rod Seal 12 No.s, Plunger 01 No.s, Fix Pano 5/8" 01 No.s, Boki 03 No.s, Plumbing bag 01 No.s)	1.00	No.s		
22	Fitting Charges of Hand Pump Machine	Skilled Labour Charges	1.00	No.s		
23	Construction charges of Plate Form	Labour charges per unit	1.00	No.s		
Total						

Note: Unit rate for all items to be quoted by supplier on company letter heads.

Lot# 05. (40 unit) Installation of Direct Borehole Handpump with Raised Platform

Type of Scheme:		Hand Pumps (Direct), Raised Plate Form (4ft X 5ft x 1.75ft)				
S.No	Item	Description	Qty.	Unit	Unit Rate (Rs:)	Amount (Rs:)
1	Bricks	First class bricks (9" * 3" * 4.5")	486	No.s		
2	Cement	Lucky or Pakland	4	Bags		
3	Sand	Fine Sand bolari	30	Cft		
4	Crush	Size (1/2"- 3/4") dia stone	13	Cft		
5	Gravel/Stone Ballast	Size (2"-2.5") Round Gravel	10	Cft		
6	UPVC-Pipe	4"dia Pipe Jeddah/ Al arab	12	Rft		
7	Drilling Bore	3" dia manually	60	Rft		
8	Casing Pipe	UPVC 2" dia Pipe Jeddah/ Al arab	60	Rft		
9	Suction Pipe	1.25" Dia National PVC Pipe (Weight 48-50kg / 500 rft)	40	Rft		
10	Filter /Jali 10 ft	UPVC with Colth Filter	1	No.s		
11	Elbow	4" dia UPVC	2	No.s		
12	Steel Jali	Steel 6" dia	1	No.s		
13	Hand Pump Machine (IILL - 2.5" dia)	6ft Long machine including 1ft brass cylinder (weight of cylinder is 1.5kg) with all brass accessories (Handle & stand #6 bar)	1	No.s		
14	Construction Charges	Skilled Labour (Plateform)	2	Days		
Total						

Note: Unit rate for all items to be quoted by supplier on company letter heads.

Lot# 06. (50 unit) Rehabilitation of Existing Dysfunctional Handpumps

Type of Scheme:		Major Repair Hand Pump, Plate Form (Size 4ft X 4ft x 1ft)				
S.No	Item	Description	Qty.	Unit	Unit Rate (Rs:)	Amount (Rs:)
A. Material						
1	Bricks	First class bricks (9" * 3" * 4.5")	256	No.s		
2	Cement	Lucky/Pakland OPC	3	Bags		
3	Sand	Fine Sand bolari	30	Cft		
4	Crush	1/2"- 3/4" dia stone	8	Cft		
5	Gravel/Stone Ballast	Size (2"-2.5") Round Gravel	10	Cft		
6	UPVC-Pipe	4"dia Pipe Jeddah/Pak Al arab	12	Rft		
7	Elbow	4" dia UPVC	2	No.s		
8	Steel Jali	6" dia	1	No.s		
9	Hand Pump Machine (IILL 2.5"dia)	6 ft Long pipe including 1ft Cylinder brass weight of cylinder is 1.5 kg with all brass accessories	1	No.s		
Sub Total						
B. Labour						
1	Fixing of Hand Pump Machine	Skilled Labour	1	No.s	600	
2	Construction Charges (Plate Form)	Skilled Labour	2	Days	1000	
Sub Total						
Total (A+B)						

Note: Unit rate for all items to be quoted by supplier on company letter heads.

Lot# 07. (350 unit) Construction of Pour Flush Latrines with Bathing Facilities

Type of Scheme:		Construction of Low Cost Latrine (Foundation Size 4ft X 5ft X 0.75ft)				
S.No	Item	Description	Qty.	Unit	Unit Rate (Rs:)	Amount (Rs:)
1	Bricks	1st Class bricks size (9"x4.5"x3")	159	No:		
2	Cement	OPC Lucky / Pakland	1.5	No:		
3	Hill Sand	Bolhari	12	Cft		
4	Crush	Size (1/2" - 3/4") mixed	3	Cft		
5	W.C	Indian WC medium size 22 inch (Saga/Kareem/3star)	1	No:		
6	P-Trap ceramic	P-Trap ceramic (good quality)	1	No:		
7	UPVC-PIPE 4" Dia	U PVC Pipe 4"dia Al-Jeddah Al-Arab	10	Rft		
8	Iron Door	GI iron door with angle Iron frame 12 kg of weigth and size of 2'-3" x6'-00" with frame.	1	No:		
9	Skilled Laboour		1	No:		
Total						

Note: Unit rate for all items to be quoted by supplier on company letter heads.

Note: Approved designs for all construction activities are attached.

Research and Development Foundation
Standard Model of Communal Rain Water Harvesting Tank (Locally called Tanka)

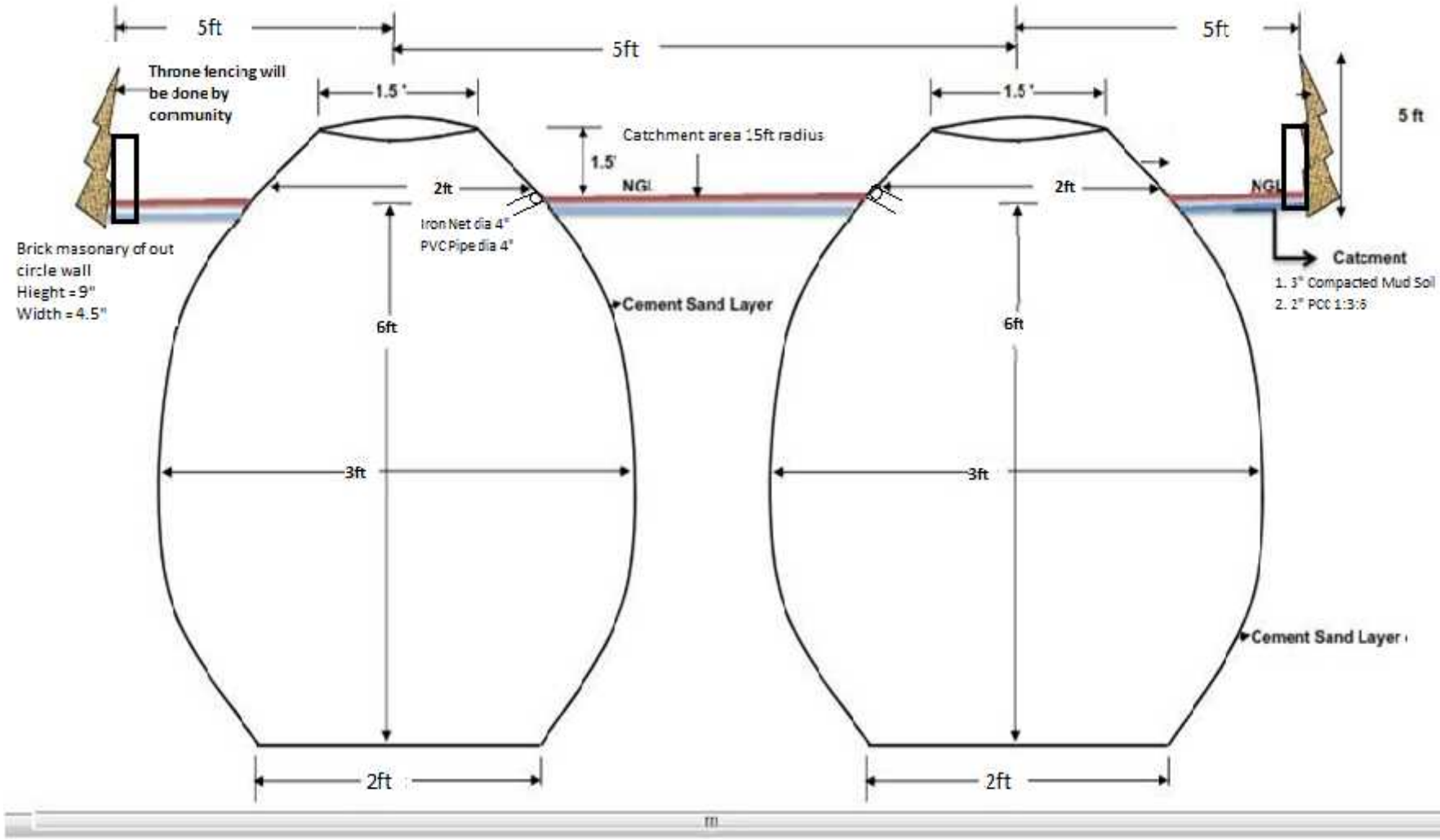

Layout Plan for Rehabilitation of Dug Well (08 Units)

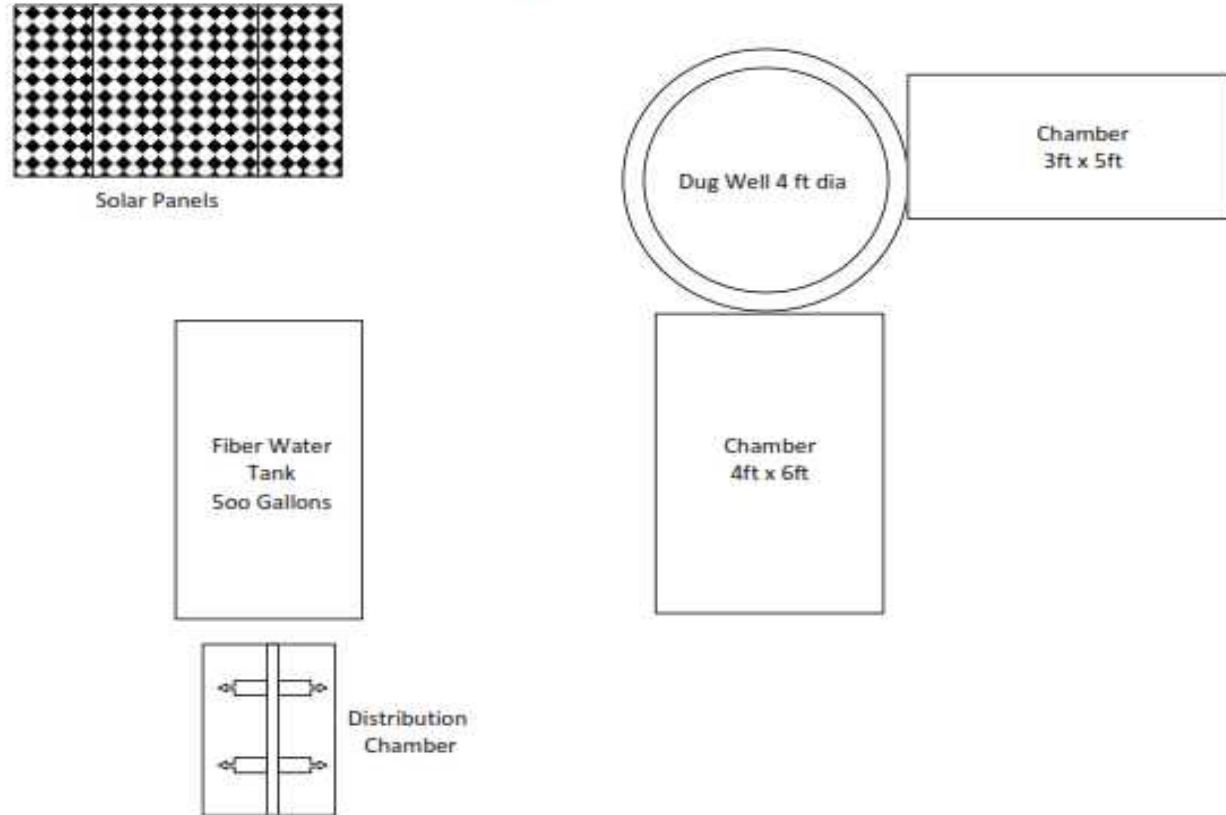

Prepared by:
Mohsin Ali Qureshi
Senior Engineer-RDF

Drawing # 01
Layout Plan for construction of Low cost latrine



Cross-section of Rehabilitation of Dug Well

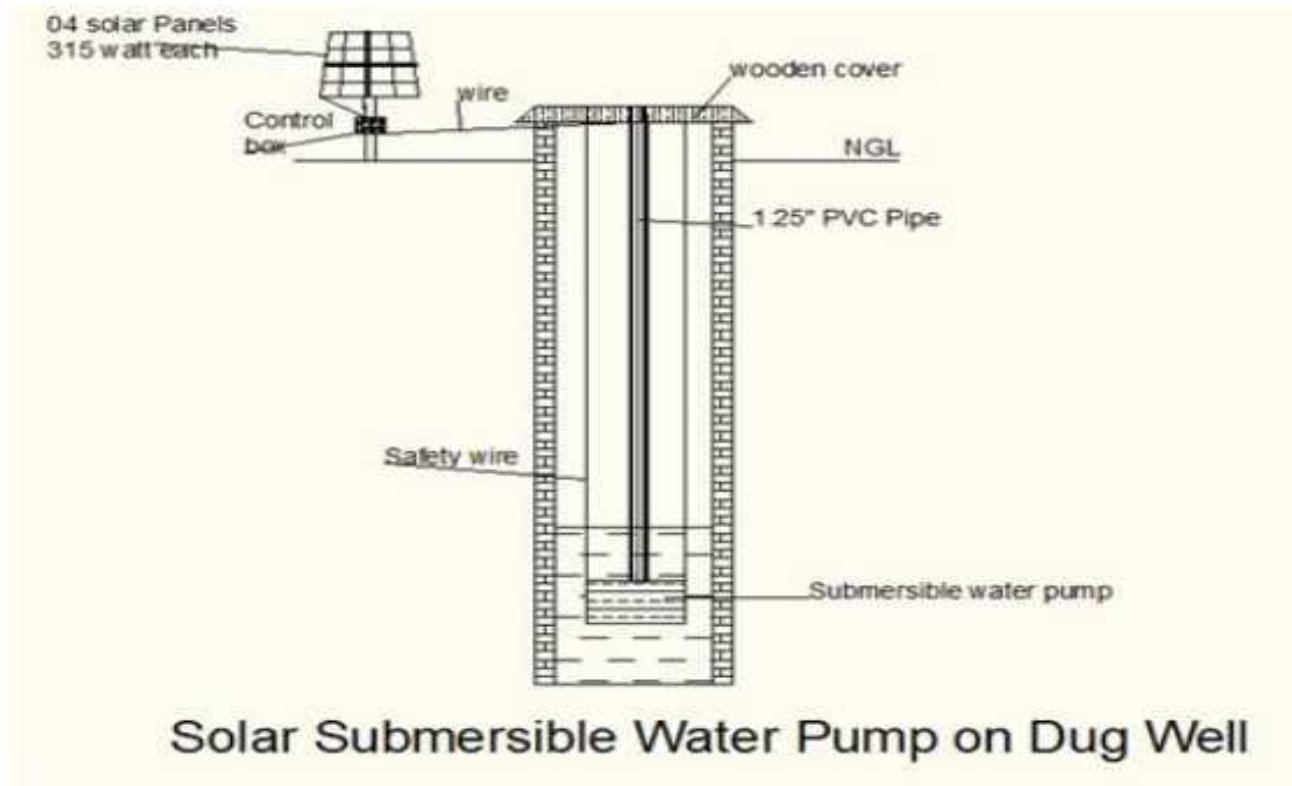

Layout Plan for Rehabilitation of Dug Well (05 Units)

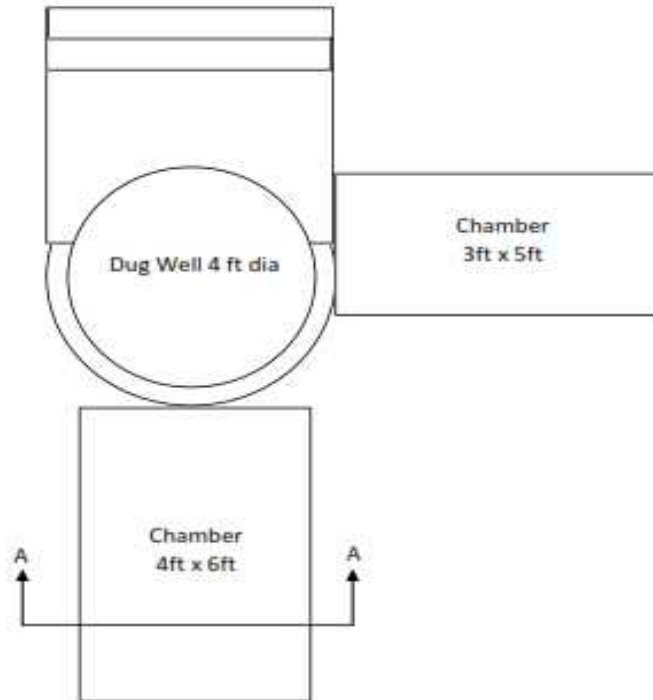

Prepared by:
Mohsin Ali Qureshi
Senior Engineer-RDF

Drawing # 01
Layout Plan for construction of Low
cost latrine



Cross-section of Rehabilitation of Dug Well

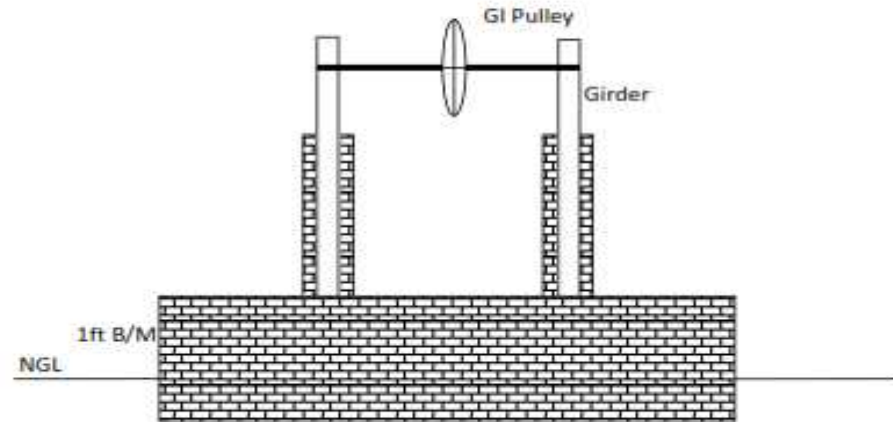
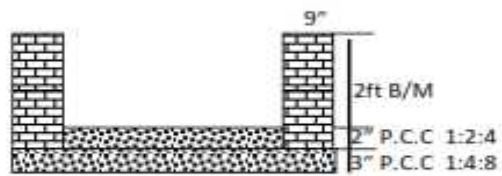

Prepared by:
Mohsin Ali Qureshi
Senior Engineer-RDF

Drawing # 02
Cross-section of Rehabilitation of
Dug Well



Layout Plan of Lead Line Hand Pump Raised Plate Form (Size 5ft x 4ft x 3ft)

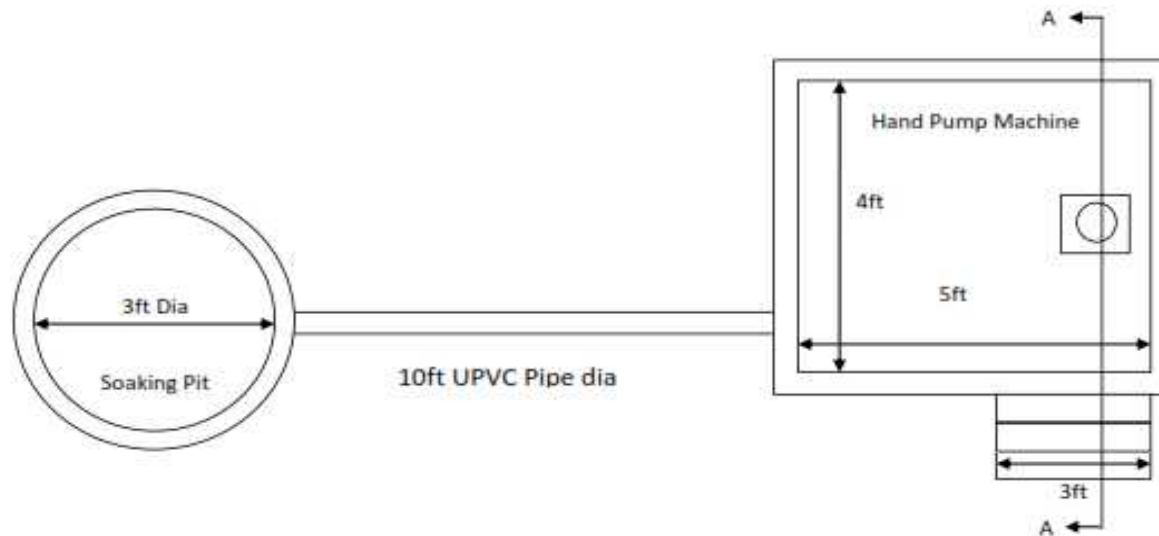

Prepared by:
Mohsin Ali Qureshi
Senior Engineer-RDF

Drawing # 01
Layout Plan of Lead Line Hand Pump
Raised Plate Form



Cross-section of Lead Line Hand Pump & Raised Plate Form

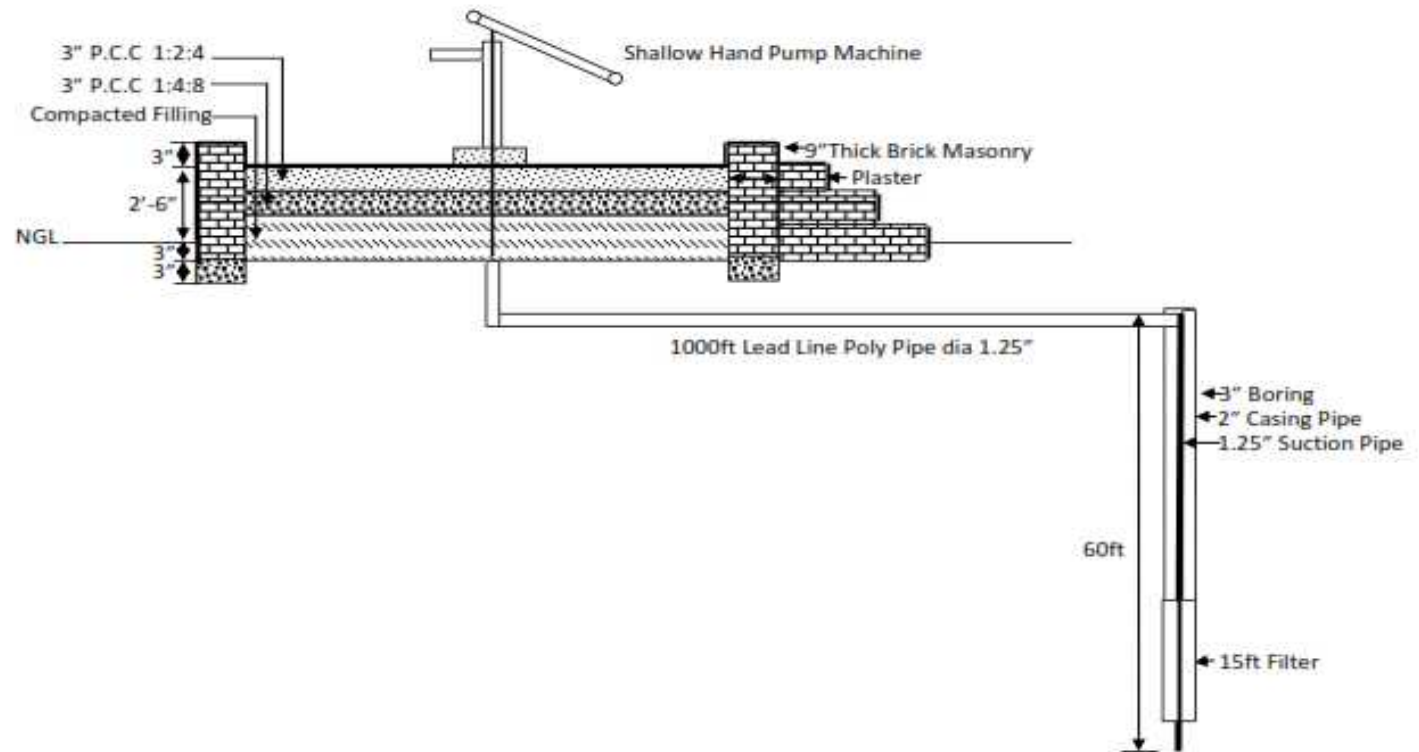

Prepared by:
 Mohsin Ali Qureshi
 Senior Engineer-RDF

Drawing # 02
 Cross-section of Lead Line Hand
 Pump Raised Plate Form



Layout Plan of Afridev Hand Pump Raised Plate Form (Size 6ft x 5ft x 2ft)

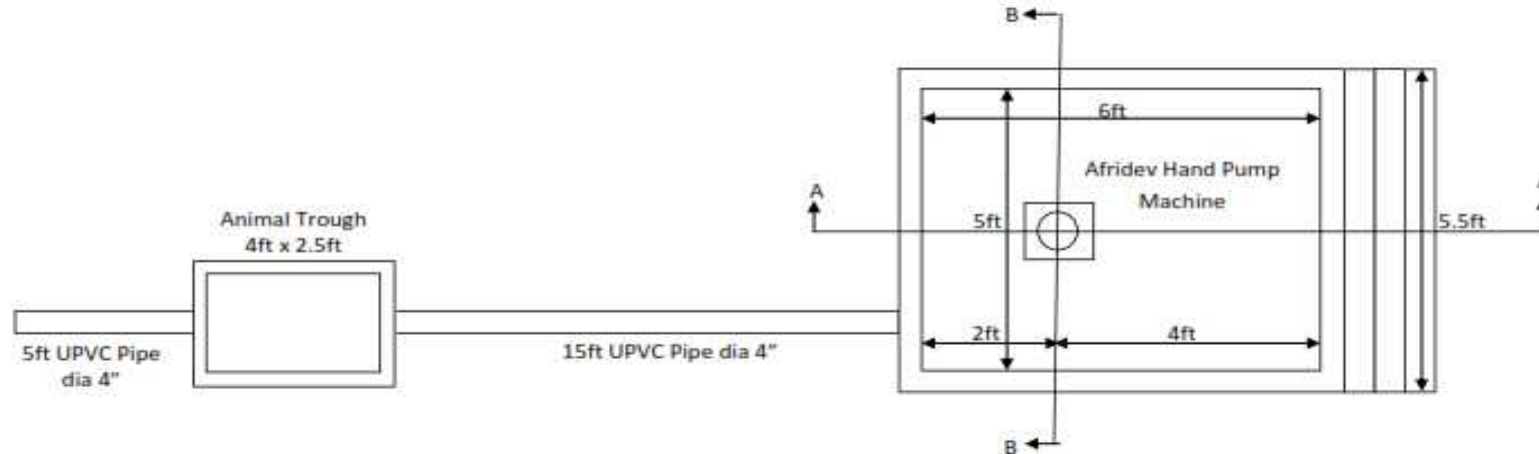

Plan of Hand Pump Raised Plate Form
(Afridev Hand Pump)

Prepared by: Mohsin Ali Qureshi
Senior Engineer-RDF

Drawing No. 01



Cross-section-AA of Hand Pump Raised Plate Form

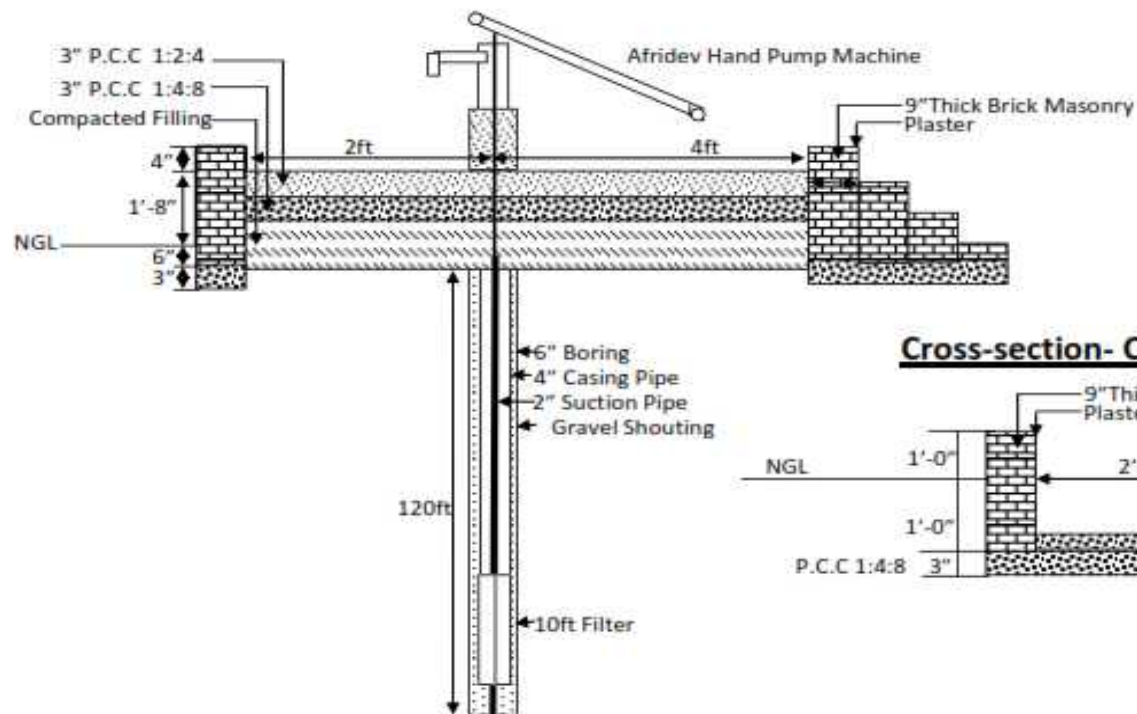

Cross-section- CC of Animal Trough

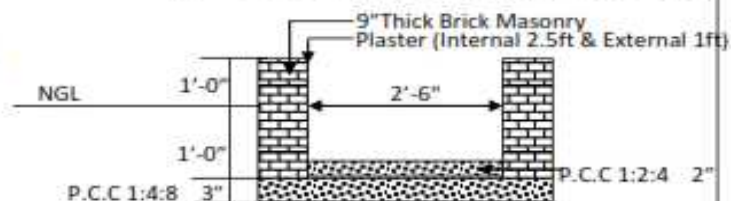

Cross-section-AA of Hand Pump Raised Plate Form (Afridev Hand Pump) & Cross-section-CC of Animal Trough

Prepared by: Mohsin Ali Qureshi
 Senior Engineer-RDF

Drawing No. 02



Cross-section-BB of Hand Pump Raised Plate Form

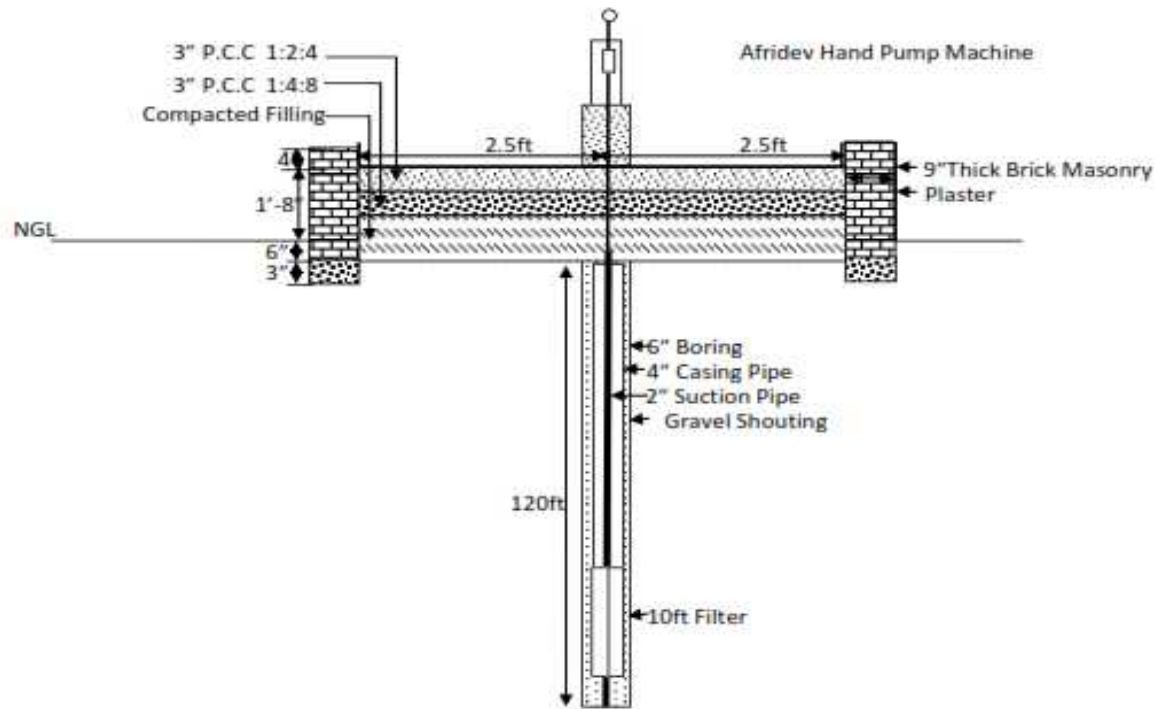

Cross-section BB of Hand Pump Raised Plate Form (Afridev Hand Pump)

Prepared by: Mohsin Ali Qureshi
Senior Engineer-RDF

Drawing No. 03



Layout Plan of Direct Hand Pump with Plate Form (Size 5ft x 4ft x 2ft)

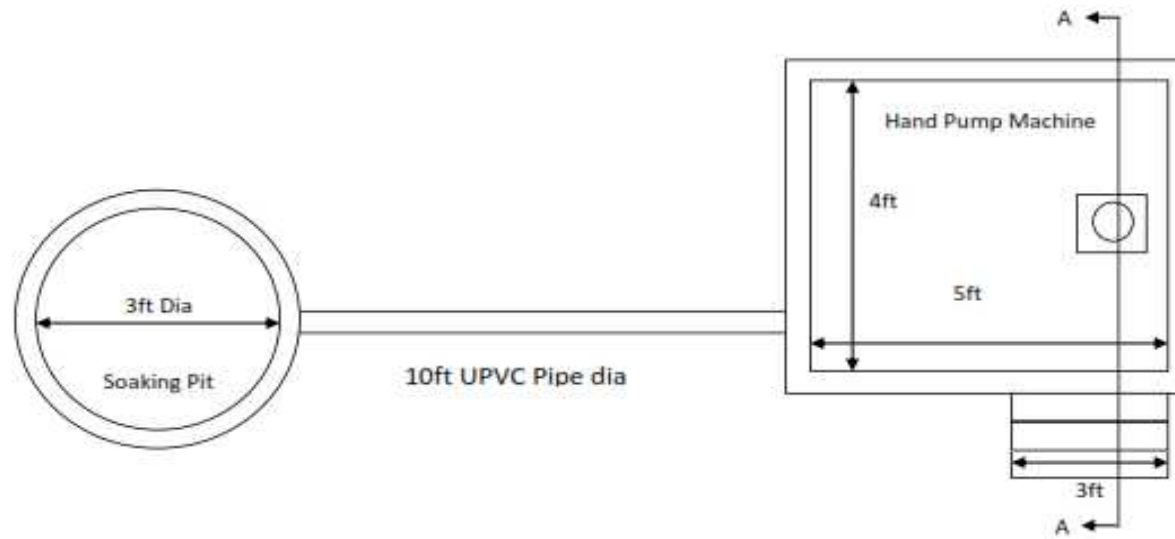

Prepared by:
Mohsin Ali Qureshi
Senior Engineer-RDF

Drawing # 01
Layout Plan of Hand Pump Plate
Form



Cross-section of Direct Hand Pump Plate Form

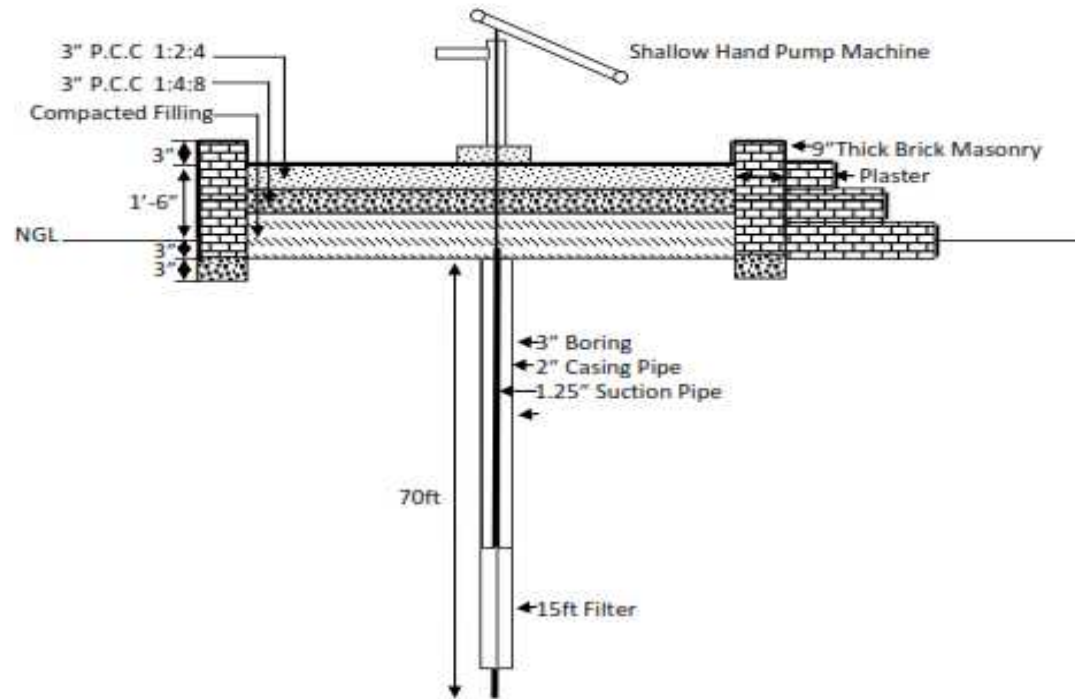

Prepared by:
 Mohsin Ali Qureshi
 Senior Engineer-RDF

Drawing # 02
 Cross-section of Hand Pump Plate
 Form



Layout Plan of Rehabilitation of Dysfunctional Hand Pump with Plate Form (Size 4ft x 4ft x 1ft)

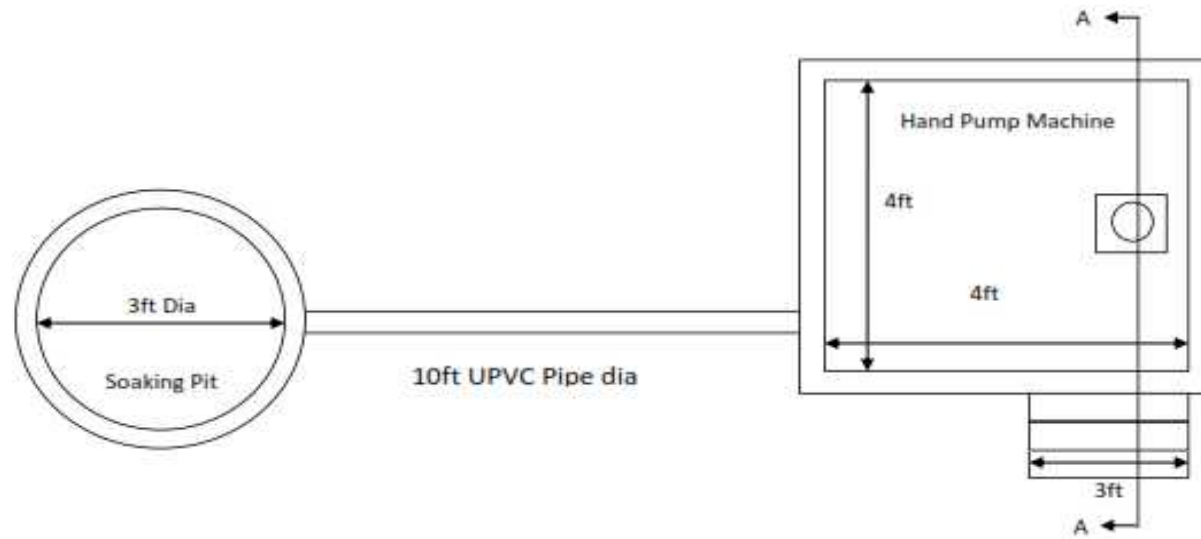

Prepared by:
Mohsin Ali Qureshi
Senior Engineer-RDF

Drawing # 01
Layout Plan of Hand Pump Plate
Form



Cross-section of Repair Hand Pump Plate Form

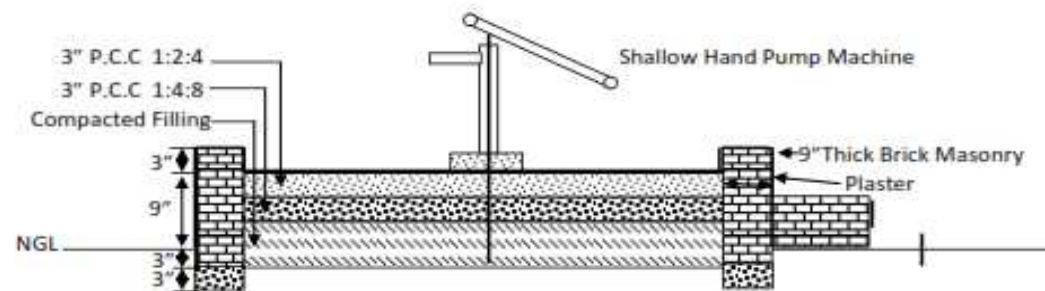

Layout Plan for Construction of Low Cost Latrine (Size 4ft x 4ft x 1ft)

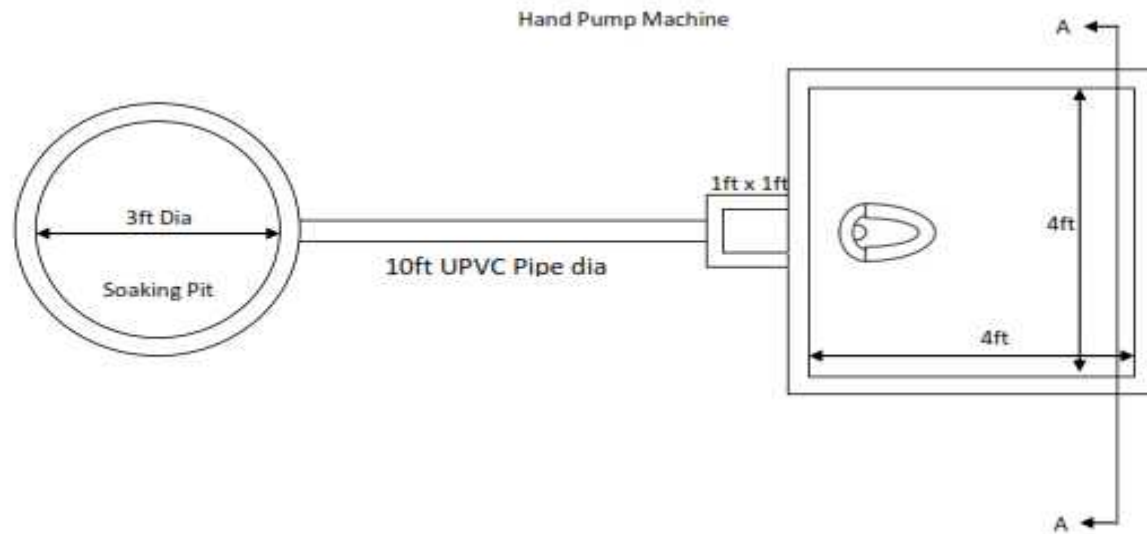

Prepared by:
Mohsin Ali Qureshi
Senior Engineer-RDF

Drawing # 01
Layout Plan for construction of Low
cost latrine



Cross-section of Repair Hand Pump Plate Form

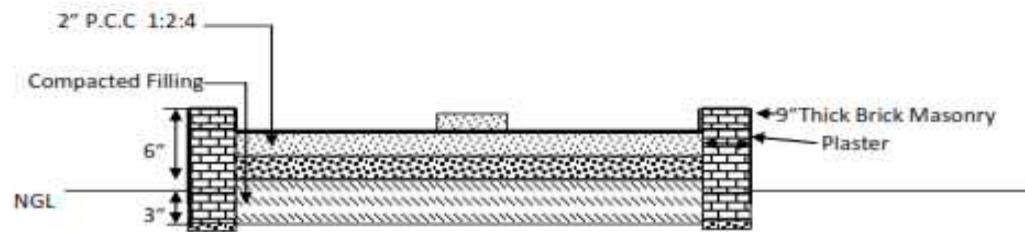

Prepared by:
Mohsin Ali Qureshi
Senior Engineer-RDF

Drawing # 02
Cross-section of Hand Pump Plate
Form



The Management structure: Procurement Committee is authorised to recommend for contract for approval by Executive Director. Contractor shall report to Project Manager at RDF field office District Sanghar and Thatta about material supply and construction work.

- **TIMING, LOGISITICS AND FACILITIES**

The Contract will commence within 10-15 day after evaluation of bids and sample analyses and period of implementation shall be 3-6 months.

Contractor will be based at different field locations of district Sanghar and Thatta, Sindh for the duration of the task

No facilities will be provided by the Contracting Authority e.g. office accommodation

Contractor shall provide the services for supply and construction

- **REPORTING**

The contractor shall ensure the supply and construction after signing within the time period as per contract and inform the field staff in written correspondence about supply and construction

All delivered supplies and work done to be reported in written in English Language, contractor must bring 4 copies of delivery challans and have to submit 1 copy to community members where work done, 1 copy to RDF field staff, 1 copy to RDF Head Office and 1 copy for contractor

- **QUALIFICATION REQUIREMENTS**

1. Technical Specification

2. Signed Tenderers Declaration

3. Company Certificate of Registration

4. Completed 'Tenderers Relevant Experience Form'

5. Samples. Please note that samples provided which do not meet the minimum specifications as per the attached tender dossier, will not qualify to the final tender evaluation process.

6. Valid Tax Registration, NTN (FBR), SST (SRB) and GST.

7. Recognized bank account (RDF) will make all payments through cross cheque or through bank transfers, and show financial soundness through bank statements.

ANNEX 2: ORGANISATION AND METHODOLOGY

To be filled in by the Tenderers, in compliance with the following instructions:

Rationale

- Any comments on the Terms of Reference of importance for the successful execution of activities, in particular its objectives and expected results, thus demonstrating the degree of understanding of the Contract. Detailed list of inputs, activities and outputs. Any comments contradicting the Terms of Reference or falling outside their scope will not form part of the final Contract.
- An opinion on the key issues related to the achievement of the Contract objectives and expected results.
- An explanation of the risks and assumptions affecting the execution of the Contract.

Strategy

- An outline of the approach proposed for contract implementation.
- A list of the proposed activities considered to be necessary to achieve the contract objectives.
- A description of subcontracting arrangements foreseen, with a clear indication of the tasks that will be entrusted to a subcontractor and a statement by the Tenderer guaranteeing the eligibility of any subcontractor.

Timetable of activities

- The timing, sequence and duration of the proposed activities taking into account mobilisation time.
- Rehabilitation of Institutional WASH Facilities. The identification and timing of major milestones in execution of the Contract, including an indication of how the achievement of these would be reflected in any reports particularly those stipulated in the Terms of Reference.
- Include a programme.

Logical frame

- A Logical frame reflecting the considerations above.

Key Experts

- The Tenderer shall include a detailed description of the role and duties of each of the key experts or other non-key experts, which the Tenderer proposes to use for the performance of the services. The key experts are those whose involvement is considered instrumental in the achievement of the Contract objectives. In addition the Tenderer shall include information on current participation of key experts in other contracts and or commitments to participate in future contracts, including detailed description of their tasks and period of engagement.

ANNEX 3: TENDER SUBMISSION FORM

The financial proposal for the required services is as follows:

Description	Quantity	Currency	Amount
Lot#01. Construction of Communal Rain Water Harvesting Tanks	75		
ot#02 Rehabilitation of dug wells	13		
ot#03 Installation of New Handpumps with Leadlines and Raised Platform	50		
ot#04 Installation of Afridev Handpumps	15		
ot#05 Installation of Direct Borehole Handpump with Raised Platform	40		
ot#06 Rehabilitation of Existing Dysfunctional Handpumps	50		
ot#07 Construction of Pour Flush Latrines with Bathing Facilities	350		
Total price incl. Taxes			

Other relevant information:

TENDERER INFORMATION	
Company (legal name)	
Street name and no.	
City	
Postal code	
Country	
Phone no.	
Email	
Website	
Director (name)	

GENERAL COMPANY INFORMATION	
Year of establishment	
Number of full time employees	
Licensing authority	
Licence number (VAT no./TAX id)	
Countries with registered office:	
International quality assurance certification held by your company	
Local and national quality assurance certification held by your company	
International trade / professional organisations of which your company is a	

member	
Local trade / professional organisations of which your company is a member	
Does your company have CSR related policies in place – e.g. Health, Safety, HR, Energy or Climate policy or is a member of Global Compact? Please state which policies.	
Does your company live up to e.g. ISO 26000/50001/14000 standards or is SA8000 certified? Please state which.	
Does your company have a Code of Conduct?	

REFERENCES				
Name and country of customer	Type of contract	Value	Contact name	Phone/fax and email

Please include details of the experience and past performance on contracts of a similar nature within the past five years and information on other contracts in hand and/or future commitments including details of the actual and effective participation in each of such contracts, description of the Tenderers assignments and periods of engagement. Additional documents can be attached to the above form.

The tender proposal is valid for period of 90 days after the closing date in accordance with the article A.9. validity, where as the contract may be signed for the required time period for implementation of work till 1 year or above.

After having read your Tender Dossier no. 02 for Material Supply and Construction Work dated 09th April 2018, and after having examined the Tender Dossier, I/we hereby offer to execute and complete the services in conformity with all conditions in the Tender Dossier for the sum indicated in our financial proposal.

On behalf of the company I/we hereby:

- Accept, without restrictions, all the provisions in the Tender Dossier including the General Terms and Conditions for Service Contracts - Ver2 2012 and the Draft Service Contract including all annexes.
- Provided that a contract is issued by the Contracting Authority I/we hereby commit to perform all services described in the Terms of Reference, Annex 1 within the time frame described in our Organisation and Methodology Form.
- Certify and attest compliance with eligibility criteria of article 33 of the General Terms and Conditions for Service - Ver2 2012.
- Certify and attest compliance with the Code of Conduct for Contractors in Annex 5.

The above declarations will become an integrated part of the Contract and misrepresentation will be regarded as grounds for termination.

Signature and stamp:

Signed by:

The Tenderer
Name of the company:
Address:
Telephone no.:
Email:
Name of contact person:

ANNEX SER 8: GENERAL TERMS AND CONDITIONS FOR SERVICE CONTRACTS – VER2 2018

1. DEFINITIONS

In these general terms and conditions:

- a) "contract" is the agreement entered into by the Contracting Authority and the Contractor for the performance of the services described in the terms of reference, to which these general terms and conditions are made applicable; the contract is constituted of the documents listed in the Service Contract.
- b) The Contracting Authority's "partners" are the organisations to which the Contracting Authority is associated or linked;
- c) "personnel" is any person assigned by the Contractor to the performance of the services or any part hereof, whether through employment, sub-contracting or any other agreement; and "key experts" are those members of the personnel whose involvement is considered instrumental in the achievement of the contract objectives;
- d) "beneficiary country" is the country where the services are to be performed, or where the project to which the services relate is located.

2. RELATIONS BETWEEN THE PARTIES

Nothing contained in the contract shall be construed as establishing a relation of master and servant or of agent and principal as between the Contracting Authority and the Contractor. Except if otherwise provided in the contract, the Contractor shall under no circumstances act as the representative of the Contracting Authority or give the impression that the Contractor has been given such authority. The Contractor has complete charge of the personnel and shall be fully responsible for the services performed by them.

3. SCOPE OF SERVICES

The scope of the services including the methods and means to be used by the Contractor, the results to be achieved by him and the verifiable indicators are specified in the Terms of Reference. The Contractor shall be responsible for everything which is required for the performance of the services in accordance with what is specified in the contract, or which must otherwise be regarded as forming part of the services.

4. COMPLIANCE WITH LAWS AND RESPECT OF TRADITIONS

The Contractor shall respect and abide by all laws and regulations in force in the beneficiary country and shall ensure that its personnel, their dependants, and its local employees also respect and abide by all such laws and regulations. The Contractor shall indemnify the Contracting Authority against any claims and proceedings arising from any infringement by the Contractor, its personnel and their dependants of such laws and regulations.

The Contractor, its personnel and their dependants shall respect human rights and undertake not to offend the political, cultural and religious practices prevailing in the beneficiary country.

5. CODE OF CONDUCT

The Contractor shall at all times act loyally and impartially and as a faithful adviser to the Contracting Authority and shall perform the services with due care, efficiency and diligence, in accordance with the best professional practice.

6. DISCRETION AND CONFIDENTIALITY

The Contractor shall treat all documents and information received in connection with the contract as private and confidential, and shall not, save in so far as may be necessary for the purposes of the performance thereof, publish or disclose any particulars of the contract without the prior consent in writing of the Contracting Authority. It shall, in particular, refrain from making any public statements concerning the project or the services without the prior approval of the Contracting Authority,

7. CONFLICT OF INTEREST

The Contractor shall refrain from engaging in any activity which conflicts with his obligations towards the Contracting Authority under the contract.

The Contractor shall take all necessary measures to prevent or end any situation that could compromise the impartial and objective performance of the Contract. Such conflict of interests could arise in particular as a result of economic interest, political or national affinity, family or emotional ties, or any other relevant connection or shared interest. Any conflict of interests which could arise during performance of the Contract must be notified in writing to the Contracting Authority without delay. The Contractor shall replace, immediately and without compensation from the Contracting Authority, any member of its personnel exposed to such a situation.

8. CORRUPT PRACTICES

The Contractor and the personnel shall refrain from performing, condoning or tolerating any corrupt, fraudulent, collusive or coercive practices, whether such practices are in relation with the performance of the contract or not. "Corrupt practice" means the offering, giving, receiving, or soliciting, directly or indirectly, of anything of value as an inducement or reward for doing or forbearing to do any act in relation to the contract or any other contract with the Contracting Authority, or for showing favour or disfavour to any person in relation to the contract or any other contract with the Contracting Authority.

The payments to the Contractor under the contract shall constitute the only income or benefit it may derive in connection with the contract and neither it nor its personnel shall accept any commission, discount, allowance, indirect payment or other consideration in connection with, or in relation to, or in discharge of, its obligations under the contract.

The execution of the contract shall not give rise to unusual commercial expenses. Unusual commercial expenses are commissions not mentioned in the contract or not stemming from a properly concluded contract referring to the contract, commissions not paid in return for any actual and legitimate service, commissions remitted to a tax haven, commissions paid to a recipient who is not clearly identified or commission paid to a company which has every appearance of being a front company.

The Contractor further warrants that no official of the Contracting Authority and/or their partner has received or will be offered by the Contractor any direct or indirect benefit arising from this Contract.

9. JOINT VENTURE OR CONSORTIUM

If the Contractor is a joint venture or a consortium of two or more legal persons, all such persons shall be jointly and severally bound to fulfil the terms of the contract. The person designated by the joint venture or consortium to act on its behalf for the purposes of this contract shall have the authority to bind the joint venture or consortium.

For the purposes of performance of the contract, the joint venture or consortium shall act as, and be considered, a single person and, in particular, shall have bank account opened in its name, shall submit to the Contracting Authority single guarantees if required, and shall submit single invoices and single reports.

The composition of the joint venture or a consortium shall not be altered without the prior written consent of the Contracting Authority.

10. SPECIFICATIONS AND DESIGNS

The Contractor shall prepare all specifications and designs using accepted and generally recognised systems acceptable to the Contracting Authority and taking into account the latest design criteria.

11. INFORMATION

The Contractor shall furnish the Contracting Authority or any person authorised by the Contracting Authority with any information relating to the services and the project as the Contracting Authority may at any time request.

12. REPORTS

The frequency, deadlines, format and contents of the reports to be drawn up by the Contractor in relation to the performance of the contract shall be described in the Terms of Reference.

13. CONTRACTOR'S PERSONNEL

13.1. The Contractor shall employ and provide such qualified and experienced personnel as are required to carry out the services, and the Contractor shall be responsible for the quality of the personnel.

The names, outputs, duties and CVs of key experts and the titles, job descriptions, minimum qualifications, estimated periods of engagement in the carrying out of the services of each of the personnel and key experts are described in the Organisation and Methodology part of the contract. The Contractor must inform the Contracting Authority of all non-expert personnel it intends to use for the implementation of the contract. The Contracting Authority shall have the right to oppose the Contractor's choice of personnel.

13.2. No changes shall be made in the personnel without the prior consent of the Contracting Authority. The Contractor shall provide a replacement with at least equivalent qualifications and experience and acceptable to the Contracting Authority if:

- a) on account of death, sickness or accident, a member of the Personnel is unable to continue providing his services,



